

# BNP<sup>®</sup> 6012P and 7212P Pressure Blast Cabinets O. M. 27724

**DATE OF ISSUE: 12/13**  
**REVISION: B, 04/19**

## **NOTICE TO PURCHASERS AND USERS OF OUR PRODUCTS AND THIS INFORMATIONAL MATERIAL**

Clemco proudly provides products for the abrasive blast industry and is confident that industry professionals will use their knowledge and expertise for the safe and efficient use of these products.

The products described in this material and the information relating to these products are intended for knowledgeable, experienced users. It is the responsibility of the employer to ensure that proper training of operators has been performed and a safe work environment is provided.

No representation is intended or made as to the suitability of the products described here for any purpose or application, or to the efficiency, production rate, or useful life of these products. All estimates regarding production rates or finishes are the responsibility of the user and must be derived solely from the user's experience and expertise, not from information contained in this material.

It is possible that the products described in this material may be combined with other products by the user for purposes determined solely by the user. No representations are intended or made as to the suitability of, engineering balance of, or compliance with regulations or standard practice of any such combination of products or components the user may employ.

This equipment is only one component of a cabinet blasting operation. Other products, such as air compressors, air filters and receivers, abrasives, equipment for ventilating or dehumidifying, or other equipment, even if offered by Clemco, may have been manufactured or supplied by others. The information Clemco provides is intended to support the products Clemco manufactures. Users must contact each manufacturer and supplier of products used in the blast operation for warnings, information, training, and instruction relating to the proper and safe use of their equipment.

© 2019 CLEMCO INDUSTRIES CORP.  
One Cable Car Dr.  
Washington, MO 63090  
Phone (636) 239-4300  
Fax (800) 726-7559  
Email: [info@clemcoindustries.com](mailto:info@clemcoindustries.com)  
[www.clemcoindustries.com](http://www.clemcoindustries.com)



**1.0 INTRODUCTION**

**1.1 Scope of Manual**

1.1.1 These instructions cover setup, operation, maintenance, troubleshooting, optional accessories, and replacement parts for BNP-6012 and 7012 series pressure blast cabinets. The instructions cover the operation of all pull-thru reclaimers and basic installation of the dust collector. One of the following supplemental manuals is provided with the dust collector. Refer to the appropriate manual for specific installation, operation, and maintenance of the collector.

- CDC-1 Dust Collectors, manual stock no. .. 28225
- RPC-2 Dust Collector, manual stock no. .... 22788
- RPH Dust Collectors, manual stock no. .... 21449

A separate owner’s manual stock no. 20951 is provided for the Sentinel Media Metering Valve.

1.1.2 The instructions contain important information required for safe operation of the cabinets. Before using this equipment, all personnel associated with the blast cabinets’ operation must read this entire manual and all accessory manuals to become familiar with their operation, parts, and terminology.

**1.2 Safety Alerts**

1.2.1 Clemco uses safety alert signal words, based on ANSI Z535.4-2011, to alert the user of a potentially hazardous situation that may be encountered while operating this equipment. ANSI's definitions of the signal words are as follows:



**This is the safety alert symbol. It is used to alert you to potential physical injury hazards. Obey all safety messages that follow this symbol to avoid possible injury or death.**

**NOTICE**

**Notice indicates information that is considered important, but not hazard-related, if not avoided, could result in property damage.**

**⚠ CAUTION**

**Caution indicates a hazardous situation that, if not avoided, could result in minor or moderate injury.**

**⚠ WARNING**

**Warning indicates a hazardous situation that, if not avoided, could result in death or serious injury.**

**⚠ DANGER**

**Danger indicates a hazardous situation that, if not avoided, will result in death or serious injury.**

**1.3 Table of Contents**

SUBJECT	SECTION LOCATION
<b>INTRODUCTION</b> .....	<b>1.0</b>
Scope of Manual .....	1.1
Safety Alerts .....	1.2
Table of Contents .....	1.3
General Description .....	1.4
Theory of Operation .....	1.5
Blast Machine and Controls .....	1.6
Dust Collector Options .....	1.7
Nozzle Options .....	1.8
Reclaimer Options .....	1.9
Metering Valve Options .....	1.10
Blasting Media .....	1.11
Compressed-Air Requirements .....	1.12
Electrical Requirements .....	1.13
<b>INSTALLATION</b> .....	<b>2.0</b>
General Installation Notes .....	2.1
Assemble Blast Machine and Reclaimer .....	2.2
Support the Blast Machine .....	2.3
Connect Conveying (flex) Hose .....	2.4
Attach Blast-Machine Exhaust Hose .....	2.5
Connect Blow-Off Hose .....	2.6
Connect Blast Hose .....	2.7
Connect Urethane Control Tubing .....	2.8
Connect Compressed-Air Supply Lines .....	2.9
Ground Cabinet and Dust Collector .....	2.10
Connect Electrical Service .....	2.11
Anchor Blast Machine .....	2.12
Set Air-Inlet Damper .....	2.13
Final Assembly .....	2.14

<b>FIELD INSTALLED ACCESSORIES</b> .....	<b>3.0</b>	Window-Gasket Replacement .....	7.5
Aluminum Oxide (aggressive media) Kit .....	3.1	Window-Frame Removal .....	7.6
Cabinet Curtains Installation .....	3.2	LED Light Assembly .....	7.7
Manometer .....	3.3	Replacing Pop-Up Valve .....	7.8
Armrest .....	3.4	Replacing Pop-Up Valve Seal .....	7.9
Turntable with Workcar and Track .....	3.5	Replacing Reclaimer Wear Plate .....	7.10
<b>OPERATION</b> .....	<b>4.0</b>	Replacing or Installing Rubber Reclaimer Liners .....	7.11
Media Loading .....	4.1	Removing or Replacing Reclaimer Inlet Baffle .....	7.12
Media Unloading .....	4.2	Sentinel Metering Valve .....	7.13
Loading and Unloading Parts .....	4.3	Reverse-Pulse Dust Collector .....	7.14
Blasting Operation .....	4.4	<b>TROUBLESHOOTING</b> .....	<b>8.0</b>
Operation and Function of the Choke Valve .....	4.5	Poor visibility .....	8.1
Blasting Technique .....	4.6	Abnormally high media consumption .....	8.2
Stop Blasting .....	4.7	Reduction in blast cleaning rate .....	8.3
Shutdown .....	4.8	Plugged nozzle .....	8.4
<b>ADJUSTMENTS</b> .....	<b>5.0</b>	Media bridging .....	8.5
Blasting Pressure (pilot regulator) .....	5.1	Media surge .....	8.6
Media Metering (media flow) .....	5.2	Air only (no media) comes out the nozzle .....	8.7
Reclaimer Static Pressure .....	5.3	Neither media nor air comes out the nozzle .....	8.8
Optional Externally Adjustable Vortex Cylinder .....	5.4	Blast machine does not pressurize .....	8.9
Door Interlocks .....	5.5	Blast machine does not depressurize .....	8.10
Cabinet Air-Inlet Damper .....	5.6	Heavy media flow .....	8.11
Optional Manometer .....	5.7	Media buildup in cabinet hopper .....	8.12
<b>PREVENTIVE MAINTENANCE</b> .....	<b>6.0</b>	Static shocks .....	8.13
Daily Inspection and Maintenance Before Blasting .....	6.1	Dust leaking from cabinet .....	8.14
Check media level .....	6.1.1	Dust leaking from dust collector .....	8.15
Inspect reclaimer debris screen and door gasket ..	6.1.2	<b>ACCESSORIES AND REPLACEMENT PARTS</b> .....	<b>9.0</b>
Compressed-air filter .....	6.1.3	Optional Accessories .....	9.1
Inspect couplings .....	6.1.4	Cabinet Replacement Parts .....	9.2
Inspect dust container .....	6.1.5	View Window .....	9.3
Daily Inspection During Blasting .....	6.2	LED Light Assembly .....	9.4
Inspect blast hose couplings and nozzle holder ...	6.2.1	Foot Pedal .....	9.5
Inspect blast machine .....	6.2.2	1" Diaphragm Outlet Valve .....	9.6
Check cabinet for dust leaks .....	6.2.3	Plumbing and Cabinet Controls .....	9.7
Check dust-collector exhaust air for dust .....	6.2.4	Blast Machine .....	9.8
Drain pulse reservoir .....	6.2.5	Sentinel Valve Replacement Parts .....	9.9
Cartridge pulsing .....	6.2.6	Flex Hose and Wye Pipe, and Adaptors .....	9.10
Weekly Inspection and Maintenance Before Blasting ..	6.3	Replacement Reclaimer Assemblies .....	9.11
Inspect view-window cover lens .....	6.3.1	900 cfm Reclaimer, for 16" Dia. Blast Machine .....	9.12
Inspect gloves .....	6.3.2	1200 cfm Reclaimer, for 16" Dia. Blast Machine .....	9.13
Inspect blast hose .....	6.3.3	<b>1.4 General Description</b>	
Inspect nozzle .....	6.3.4	<b>1.4.1</b> BNP blast cabinets enclose the blasting	
Inspect outlet valve .....	6.3.5	environment to provide efficient blasting while	
Weekly Inspection During Blasting .....	6.4	maintaining a clean surrounding work area. Production	
Inspect blast machine plumbing .....	6.4.1	rates are influenced by size of nozzle, compressor	
Inspect flex hoses .....	6.4.2	output, working pressure, type and size of media, angle	
Monthly Inspection and Maintenance .....	6.5	and distance of the nozzle from the blast surface. BNP	
Inspect reclaimer wear plate or liners .....	6.5.1	pressure cabinets consist of four major components:	
Inspect pop-up valve .....	6.5.2	• Cabinet Enclosure	
Inspect pop-up seal .....	6.5.3	• Reclaimer	
Dust Collector .....	6.6	• Blast Machine	
<b>SERVICE MAINTENANCE</b> .....	<b>7.0</b>	• Dust Collector	
Gloves .....	7.1		
Blast Hose and Nozzle .....	7.2		
View-Window Cover Lens .....	7.3		
View-Window Replacement .....	7.4		

**1.4.2 Cabinet enclosure:** This manual covers two BNP cabinet sizes.

**BNP-6012** Approximate work chamber dimensions:  
58" wide x 58.5" deep x 53" high.

**BNP-7212** Approximate work chamber dimensions:  
69" wide x 70.5" deep x 63" high.

**1.4.3** Refer to Figure 1 for arrangement of components with a CDC-1 Dust Collector. The illustration shows 900 cfm reclaimer mounted atop the blast machine; the larger 1200 and 1800 reclaimer is mounted in the same manner but supported by legs. Figure 2 shows the arrangement with an RPC-2 reverse-pulse dust collector with dust drawer. The optional RPH is set up the same way as the RPC-2, but includes a hopper for additional dust storage and empties into a drum. The overall height of an RPH-2 is approximately 10.5 ft and 12 ft when the top access door is open. To upgrade, an RPC-2 or RPH-2 collector may be added at any time.

## 1.5 Theory of Operation

**1.5.1** Once the components are correctly set up and turned ON, the cabinet is ready for operation by actuation of the foot pedal. Fully depressing the foot pedal pressurizes the blast machine, causing media to be propelled through the blast hose and out the nozzle. After striking the object being blasted, the blast media, fines, dust, and byproducts generated by blasting fall through the grate into the cabinet hopper. These particles are then drawn into the reclaimer for separation. Dust and fines are first separated from reusable media and pass into the dust collector. Next, reusable media is screened for oversize particles and returned to the reclaimer for reuse. Dust and fines entering the dust collector are removed from the air stream as they pass through the filters, discharging clean air. When the foot pedal is released, the blast machine depressurizes and blasting stops. Media stored in the reclaimer automatically refill the blast machine when blast machine pressure equalizes and the pop-up valve drops.

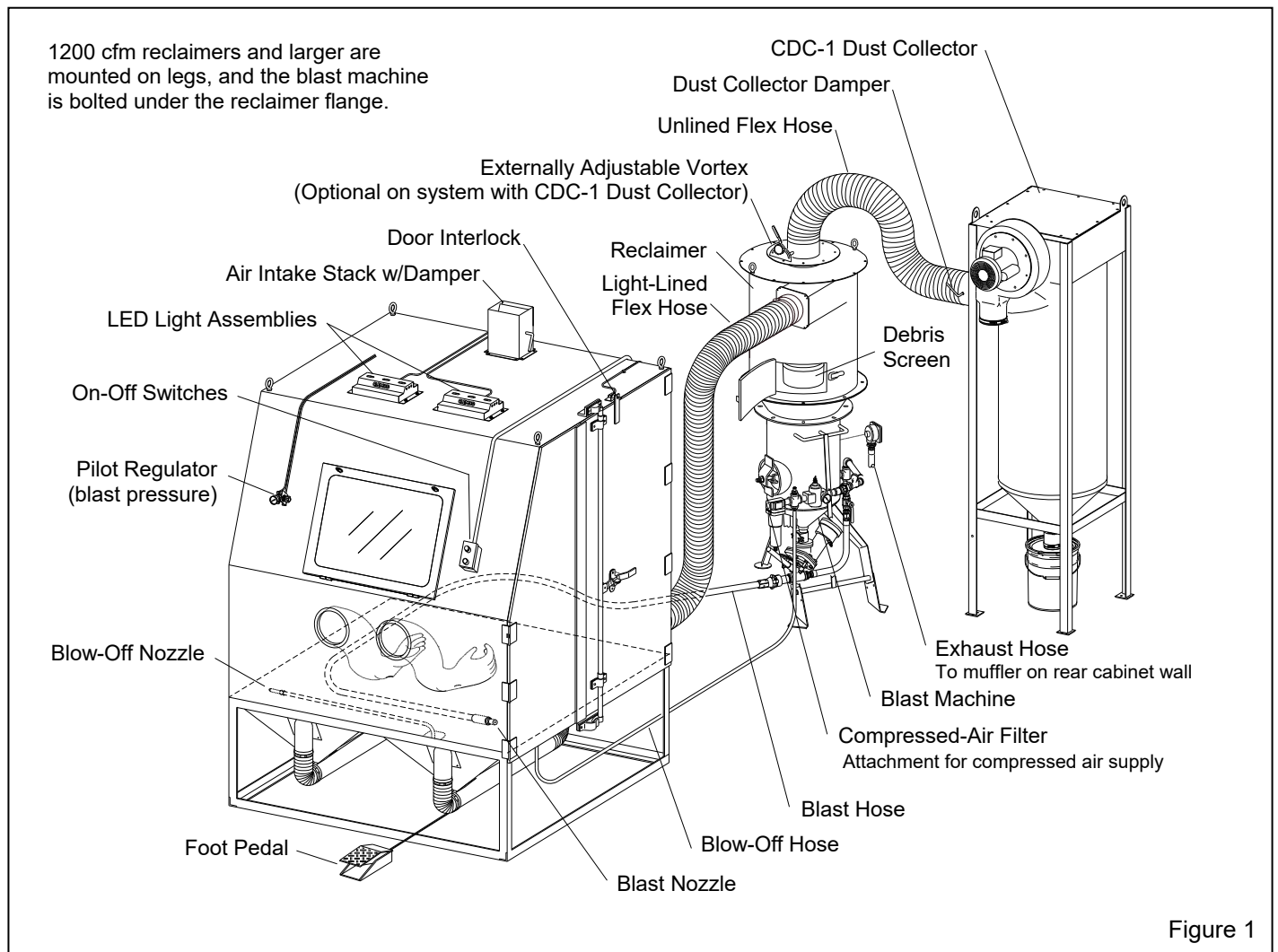

## 1.6 Blast Machine and Controls

**1.6.1** Clemco certifies that its blast machines (pressure vessels) conform to the ASME (American Society of Mechanical Engineers) Boiler and Pressure Vessel Code, Section VIII, Division 1. It is the owner's responsibility to maintain the integrity of the vessel in accordance with state regulations. Regulations may include regular inspection and hydrostatic testing as described in National Board inspection code and jurisdictional regulations and/or laws.

### **⚠ WARNING**

**Welding, grinding, or drilling on the blast machine can weaken the vessel. Compressed-air pressure can cause a weakened blast machine to rupture, resulting in death or serious injury. Welding, grinding, or drilling on the vessel without a National Board R stamp voids the Clemco ASME certification.**

**1.6.2** All welding repairs to the vessel must be performed by certified welders at shops holding a National Board R stamp. Welding performed by any welder not properly qualified per the ASME code voids the Clemco ASME certification.

**1.6.3** Do not exceed the maximum working pressure rating (PSI) of the blast machine. The maximum pressure rating is stamped into the ASME nameplate, which is welded to the side of the vessel.

### **⚠ WARNING**

**Excessive compressed-air pressure can cause a blast machine to rupture. To prevent serious injury or death, do not exceed the rated pressure of the blast machine.**

**1.6.4** OSHA does not require pressure-relief valves on blast machines when air compressors supplying air to the blast machines are built to American Society of Mechanical Engineers Boiler and Pressure Vessel Code, Section VIII, Division 1 and comply with OSHA regulation 29 CFR 1910.169, which refers to the ASME code when describing the necessity of pressure-relief valves on compressed-air equipment. **DO NOT** operate blast machines with air compressors that are not equipped with properly functioning pressure-relief valves with maximum pressure less than or equal to the maximum-allowable working pressure (MAWP) stamped on the vessel nameplate.

**1.6.5** When the cabinet is set up, the blast machine is ready to blast by actuating the foot pedal. Pressing the foot pedal opens the normally closed main inlet regulator and closes the normally open outlet valve. The incoming air pressurizes the blast machine, and blasting begins. When pressure on the foot pedal is released, the blast machine depressurizes, and blasting stops.

## 1.7 Dust Collector Options

**1.7.1 CDC-1 Dust Collectors:** Shown in Figure 1, the collector is available for 900 cfm models. The single filter cartridge is cleaned by using a manually controlled pulse of compressed air. Dust collects in a 5-gallon dust drum, which must be frequently emptied. CDC-1 Dust Collectors are standard with BNP cabinets with 900 cfm reclaimers unless an optional RPC-2 or RPH dust collector is ordered at time of purchase. Refer to manual number 28225.

**1.7.2 RPC-2 Dust Collectors:** Shown in Figure 2, this collector is available in 900 cfm models for use with BNP-6012 and 7212 cabinets. Dual filter cartridges are automatically cleaned by a timed, periodic pulse of compressed air. Dust collects in the drawer, and it must be frequently emptied. Refer to manual number 22788.

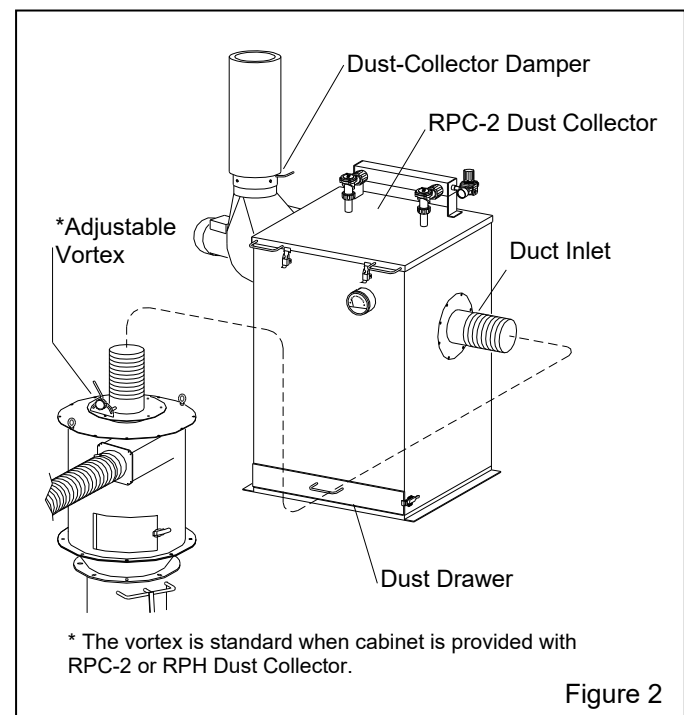

**1.7.3 RPH Dust Collector:** The RPH-2 (900 cfm) and RPH-3 (1200 cfm) are set up and operate the same as the RPC-2, as shown in Figure 2, but instead of a dust drawer, the collector sits atop a hopper, which provides additional dust storage, and empties into a drum. An

RPH is standard with 1200 cfm models. Refer to manual number 21449.

## **▲ WARNING**

**All dust is hazardous to breathe. Emissions can occur from the dust collection system. Identify all materials that are to be removed by blasting; if any toxic materials such as lead dust or dust from other heavy metals and corrosives, or any other toxic materials are being removed, use a HEPA afterfilter to assist in maintaining inhalation hazards below the permissible exposure limits (PELs). Prolonged exposure to any dust can result in serious lung disease and death. Short-term ingestion of toxic materials can cause serious respiratory injury or death. Filtration may not be adequate in reducing all inhalation hazards. It remains the employer's or user's responsibility to ensure all emissions are safe to breathe.**

**1.7.4 HEPA (high-efficiency particulate air) Filter:** Optional HEPA afterfilters provide additional filtration and must be used with a reverse-pulse cartridge collector when removing toxic coatings, heavy metals, or any other toxic materials. Refer to the applicable dust collector manual noted in Paragraph 1.1.1 for the HEPA option.

### **1.8 Nozzle Options**

**1.8.1** Unless otherwise specified at the time of purchase, cabinets are provided with a 3/16" orifice tungsten carbide nozzle. Optional 1/8", 1/4", and 5/16" orifice nozzles are also available. The reclaimer size determines the maximum-allowable nozzle size. The table in Figure 3 shows the maximum nozzle size recommended under normal conditions.

RECLAIMER SIZE	MAXIMUM NOZZLE SIZE
900 cfm	1/4" orifice
1200 cfm	5/16" orifice
1800 cfm	5/16" orifice

#### **NOTICE**

Nozzles larger than 1/4" will substantially increase wear on standard 1/2" ID blast hose. Optional 3/4" Supa hose should be used with 5/16" nozzles.

Figure 3

Normal conditions are moderate part contamination, media breakdown, media flow, media size, and damper setting, and are further explained within the contents of the manual.

**1.8.2** Nozzles with an orifice larger than those recommended could cause air leakage from the cabinet and impair recovery from the cabinet hopper. 5/16" orifice nozzles will substantially increase wear on 1/2" blast hose. Use optional 3/4" Supa hose with 5/16" nozzles. Refer to Section 9.1: *Optional Accessories*.

**1.8.3** Use boron carbide nozzles when blasting with aggressive media, as noted in Section 1.11.4. Nozzles lined with boron carbide extend nozzle wear life. Refer to Section 9.1: *Optional Accessories*.

### **1.9 Reclaimer Options**

**1.9.1** A 900 cfm pull-thru reclaimer utilizes a CDC-1 Reverse-Pulse Dust Collector or optional RPC-2 or RPH-2 Dust Collector.

A 1200 cfm reclaimer utilizes a RPH-3 Reverse-Pulse Dust Collector.

Cabinets with 1800 cfm reclaimers and RPH-4 Dust Collectors are available by special order. Refer to Figure 4 for 1800 cfm applications.

**1.9.2 Replaceable rubber reclaimer liners:** Replaceable rubber reclaimer-liners prolong service life of the reclaimer and should be installed when using silicon carbide, aluminum oxide, or other aggressive media, as noted in Section 1.11.4. Rubber liners are available for a reclaimer that has a removable top and designed to accept liners. Reclaimer liners are shown in Section 9.1, Figure 41.

**1.9.3 Externally adjustable vortex option:** The vortex fine-tunes media separation; refer to Section 5.4 for additional information. The vortex is an option on 900 cfm cabinets with a CDC-1 Dust Collector but is standard on reclaimers when the cabinet is provided from the factory with an RPC or RPH Dust Collector.

### **1.10 Metering Valve Options**

**1.10.1** Unless specified at the time of purchase, cabinets are supplied with a fine-mesh Sentinel metering valve. The valve is for use with 50-mesh and finer media, and #10 and finer glass bead. The optional Sentinel metering valve is recommended when using media coarser than 50-mesh. Conversions kits listed in Section 9.1 easily convert the valves.

## 1.11 Blasting Media

**1.11.1** Always use media specifically manufactured for blasting and that are compatible with the surface being blasted. Media produced for other applications may be inconsistent in size and shape, contain particles that could jam the media metering valve, or cause irregular wear. Always obtain the safety data sheet (SDS) for the blasting media prior to blasting and identify material being removed by blasting, paying particular attention to worker health risks and presence of any hazardous/toxic substances.

Most common reusable media (with the appropriate metering valve, as noted in Paragraph 1.10) specifically manufactured for blasting can be used in ZERO cabinets. The listing of media sizes shown in this section and in Figure 4 are provided as a guideline only. The guideline is based on standard 3/16" orifice nozzle and average conditions with variables such as blast pressure, media-air mixture, visibility inside the cabinet, humidity, and reclaimer cleaning-rate.

Several variables that affect the reclaimer cleaning-rate include reclaimer size (cfm), contamination of parts being blasted, media friability, damper setting (static pressure), and dust-collector filter loading (differential pressure across the dust filters).

As a rule, larger nozzles deliver more media, requiring higher performance from the reclaimer. When using larger nozzles, the maximum mesh size of media will be smaller than normally recommended. Using media finer than those recommended may decrease visibility and, at some point, carry over to the dust collector. Media coarser than those recommended may be too dense for the reclaimer to recover from the cabinet hopper.

**1.11.2 Steel shot and steel grit:** Steel shot or steel grit may be used in BNP cabinets configured for using steel media. Refer to Figure 4 for steel media limitations.

Using steel media requires a smaller diameter conveying hose (usually reduced one size from standard) and a 1200 cfm or larger reclaimer. Steel grit or shot is too heavy to use with cabinets equipped with a 900 cfm reclaimer. Rubber curtains should be used to protect the cabinet walls from peening and rapid wear. For these applications, cabinets can be ordered with reduced-size flex hose appropriately sized for steel, and with rubber curtains installed. They may also be field installed later. *Refer to Section 9.1: Optional Accessories.* NOTE: Steel grit or shot is too heavy to use with cabinets equipped with 900 cfm reclaimers.

**1.11.3 Sand and slag:** Sand and slag media are not suitable for cabinet use. Sand should NEVER be used for media blasting because of the respiratory hazards associated with media containing free silica. Slags are not recommended because they rapidly break down and are not recyclable.

**1.11.4 Silicon carbide, aluminum oxide, and garnet:** These are the most aggressive of the commonly used media. Aggressive media may be used, but the service life of any components exposed to the media will be reduced. To avoid unscheduled downtime and maximize cabinet life, periodically inspect the reclaimer wear plate, blast hose, and nozzle for wear and replace parts as needed.

When using aggressive media only occasionally, install an optional aluminum oxide kit, which includes rubber curtains for the cabinet interior and a boron carbide-lined nozzle. When using aggressive media on a regular basis, install the aluminum oxide kit and a fully-rubber-lined reclaimer. NOTE Rubber-lined reclaimers are available as factory-installed items, or field-installed liners can be installed later on reclaimers if they have removable tops and are designed to accept liners. Nozzles lined with boron carbide extend nozzle wear life. *Refer to Section 9.1: Optional Accessories.*

This guideline to media selection is based on standard 3/16" orifice nozzle (3/8" with plastic and similar weight media blasting at low pressure) and average conditions, such as air pressure, media-air mixture, visibility, contamination of parts being cleaned, humidity, media friability, reclaimer cleaning rate, etc. As a rule, larger nozzles deliver more media, requiring higher performance from the reclaimer. Larger nozzles decrease the maximum mesh size of media from those recommended. Media that is finer than those recommended may decrease visibility and, at some point, carry over to the dust collector. Media coarser than those recommended may be too dense for the reclaimer to recover from the cabinet hopper.

RECLAIMER SIZE	MEDIA TYPE				
	STEEL GRIT	STEEL SHOT	PLASTIC	GLASS BEAD	ALUM. OXIDE
900 cfm with 6" inlet	Do not use	Do not use	N/A See 1.10.8	No. 8 to No. 12	54 to 180-Mesh
1200 cfm with 6" inlet	50 to 120	S-230 to S-70	Do not use	No. 4 to No. 8	16 to 60-Mesh
1200 cfm with 7" inlet	Do not use	Do not use	N/A See 1.10.8	No. 4 to No. 12	46 to 180-Mesh
1800 cfm with 7" inlet	25 to 120	S-280 to S-70	Do not use	No. 4 to No. 8	16 to 60-Mesh
1800 cfm with 8" inlet	Do not use	Do not use	N/A See 1.10.8	No. 4 to No. 12	36 to 180-Mesh

Figure 4

**1.11.5 Glass bead:** Most beads are treated to ensure free-flow operation, even in environments of moderately high humidity. Glass beads subjected to excessive moisture may be reused only after thoroughly drying and breaking up of any clumps.

**1.11.6 Lightweight and fine-mesh media:** When using lightweight (such as agricultural) media or fine-mesh (180-mesh and finer) media, the reclaimer inlet baffle may need to be removed to retain media and avoid carryover. On reclaimer models with bolt-on removable tops, baffle removal and replacement is easily accomplished. Reclaimers with welded-on tops require grinding to remove the baffle and **once it is removed it cannot be replaced.**

**1.11.7 Plastic media:** Plastic media requires a blast machine with a 60-degree conical bottom. Refer to Clemco's Aerolyte® cabinet brand.

**1.11.8 Bicarbonate of soda:** Bicarbonate of soda is not recommended for use in standard cabinets. Bicarb is a one-use media, which will quickly saturate the filter cartridge(s). Refer to Clemco's Aerolyte cabinet line for cabinets that are specifically designed for use with bicarbonate of soda.

## 1.12 Compressed-Air Requirements

**1.12.1** The size of the compressor required to operate the cabinet depends on the size of the nozzle and blasting pressure. Unless otherwise specified, cabinets are supplied with a 3/16" orifice nozzle. The table in Figure 5 shows air consumption of nozzles when new. It does not show the recommended compressor size. As nozzles wear, they will consume up to 70% to 80% more air. Consult with a compressor supplier for a suggested compressor size based on the air consumption. **NOTE: A separate air line is required for the reverse-pulse dust collector; refer to the dust collector owner's manual.**

Nozzle size	Air Pressure (psi)			
	50	60	70	80
1/8"	11	13	15	17
3/16"	26	30	33	38
1/4"	47	54	61	68
5/16"	77	89	101	113

\* Figures are approximate and for reference only, and may vary for different working conditions. Several variables, including media flow and nozzle wear, affect cfm consumption.

Figure 5

**1.12.2** The air filter at the blast machine inlet removes condensed water from the compressed air. The filter automatically drains when moisture fills the bowl to a certain level. Its use is especially important in areas of high humidity or when fine-mesh media are used. Moisture causes media to clump and inhibits free flow through the metering valve. If the filter does not remove enough moisture to keep media dry and flowing, it may be necessary to install an air dryer or aftercooler in the air-supply line.

## 1.13 Electrical Requirements

All wiring external to the cabinet is provided by the user to comply with local electrical codes.

**1.13.1** Electrical requirements depend on the size and phase of the dust-collector exhaust motor. NOTE: Full-load amps (FLA) shown below are for the motor only; the lights draw less than one amp. Standard cabinets are supplied as follows:

900 cfm: 2 HP, 208/230/460V, 3 PH, 60 HZ

Supplied with 230-volt control panel unless 460-volt is specified at the time the order is placed.

FLA 208/5.5, 230/5.6, 460/2.8.

1200 cfm reclaimer: 5 HP, 208/230/460V, 3-PH, 60 HZ

Supplied with 230-volt control panel unless 460-volt is specified at the time the order is placed.

FLA 208/12 to 13, 230/12 to 13, 460/6.

Additional wiring information is in Section 2.11.

## 2.0 INSTALLATION

### 2.1 General Installation Notes

**2.1.1** Refer to Figure 1 (and Figure 2 for optional reverse-pulse collector) for the general arrangement and Figure 9 for the control line schematic. Select a location where compressed air and electrical service are available. The cabinet location must comply with OSHA and local safety codes. Allow for full access to all doors and service areas and for efficient handling of large parts. Provide enough clearance in front of the dust collector to remove the dust drawer without tipping. Ideally, locate the blast machine directly behind the cabinet with the blast-hose connection toward the cabinet. The reclaimer may be rotated on the blast machine to allow for as few bends as possible to prevent wear. Determine the best location for all components and position them before making compressed-air connections, electrical connections, and attaching flex hose.



**2.1.2** The cabinet must be placed on a flat level surface. If the surface is not flat, the cabinet could flex, causing the door alignment to shift. If the floor is not level, shim the leg(s) as required to align the door.

**2.1.3** Use the eyebolts on the four top corners to lift and maneuver the cabinet. **Do not lift the cabinet from the hopper or lower frame.**

## NOTICE

**Do not use a forklift to lift the cabinet from the hoppers or lower frame. The cabinet hopper is not designed to support the weight of the cabinet. The lower frame is designed to support distributed weight. Using a forklift on the hoppers or frame may cause damage.**

**2.1.4** Refer to the dust-collector owner's manual to set up the dust collector and prepare it for operation.

## 2.2 Assemble Blast Machine and Reclaimer Figure 6.

1200 and 1800 cfm reclaimers are freestanding and mounted on support legs. **Slide the blast machine under the reclaimer, apply gasket, and bolt flanges together, as noted below.**

## WARNING

**900 cfm reclaimers weigh approximately 150 lbs. When installing or removing the reclaimer, it must be adequately supported and secured to appropriate lift equipment. Failure to secure and use proper lift device can result in injury.**

**2.2.1** Apply adhesive-backed strip gasket to the top of the flange on the blast machine. Punch out an opening at each bolt hole.

**2.2.2** If the optional storage segment is used, place it on the blast machine. The access door should be on the bottom and rotated to allow access to the door. Bolt into place. Apply adhesive-backed gasket to the upper flange, as described in Paragraph 2.2.1.

## WARNING

**Do not work under the reclaimer while it is hanging from the lifting device. Severe injury or death can occur if the reclaimer is released before it is secured to the blast machine.**

**2.2.3** Use a lift, raise the reclaimer over the blast machine assembly, and lower it in place. Attach with fasteners provided.

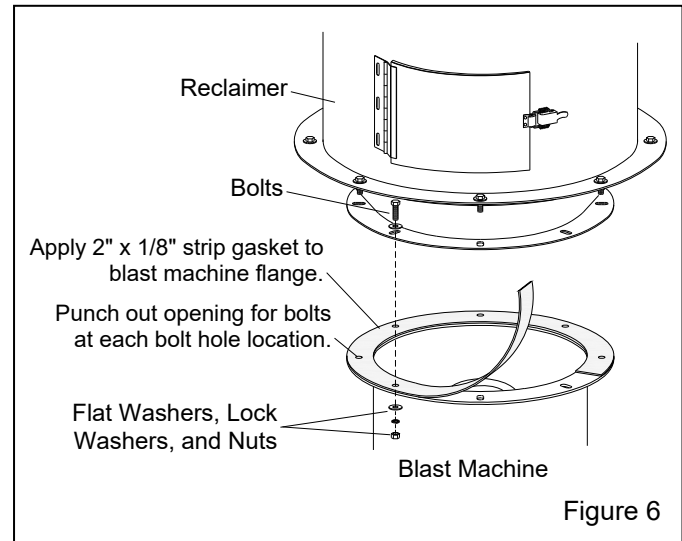

Figure 6

## 2.3 Support the Blast Machine

**2.3.1** Use chains, cables, or other means to temporarily support the blast machine and reclaimer during final assembly until the machine can be anchored,

## 2.4 Connect Conveying (flex) Hoses – Figure 7 Refer to Page 42, Figure 50 for hose sizes.

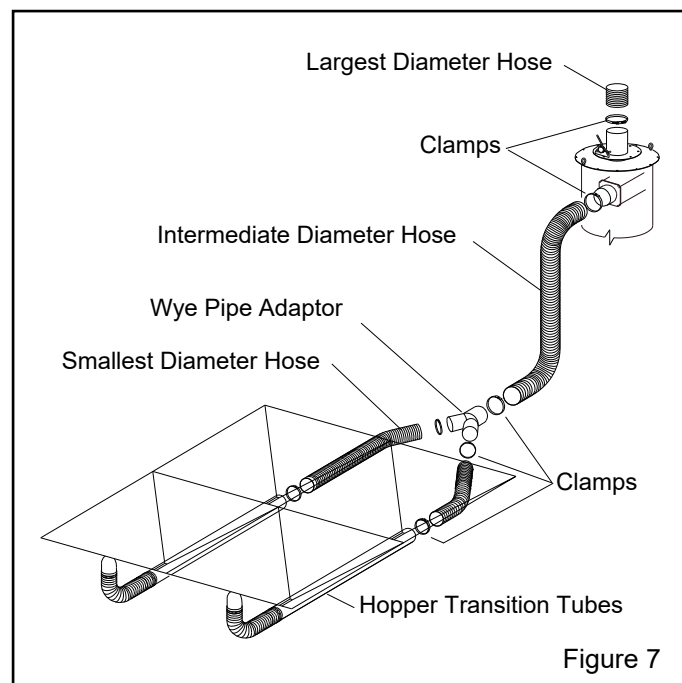

Figure 7

**2.4.1** Connect the two smallest-diameter flexible conveying hoses between the cabinet hopper transition tubes and wye pipe adaptor. It is easier to slip the hose over the adaptor and to create a tighter seal if the first two or three inches of wire are removed from the inside of the hose. Use care not to damage the hose. **NOTE: The hose wire helps dissipate static electricity in the conveying hose and helps ground each segment. In order for the hose wire to dissipate static electricity, the wire must touch the metal of each segment.** Clamp the flex hose securely with worm clamps provided.

**2.4.2** Connect the intermediate diameter flex hose between the wye pipe and reclaimer inlet adaptor. Clamp the flex hose securely with worm clamps provided.

**2.4.3** The largest diameter hose attaches to the reclaimer outlet, which will be connected later.

**2.5 Attach Blast-Machine Exhaust Hose –Figure 8**

**2.5.1** Screw the male end of the exhaust hose into the 1" coupling located on the rear cabinet wall, turning the hose as required. Connect the female swivel end to the male adaptor on the blast-machine outlet valve.

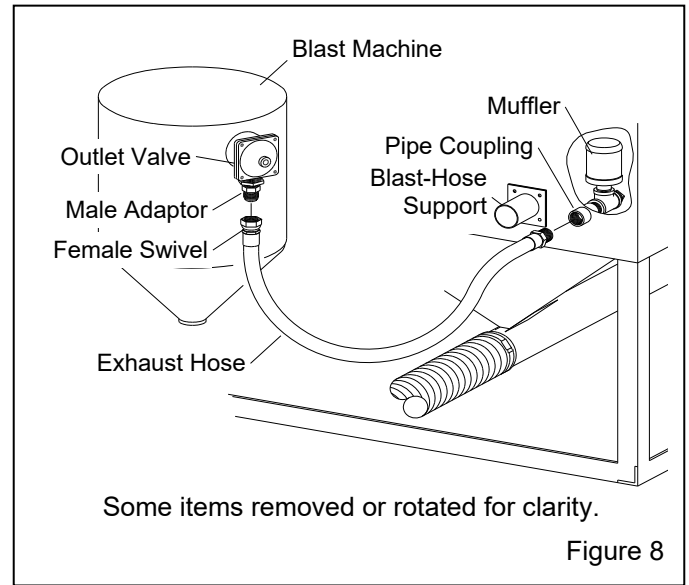

Figure 8

**2.6 Connect Blow-Off Hose**

**2.6.1** Attach the 1/2" blow-off hose coming from the cabinet hopper to the compatible fitting on the blast machine piping located between the air filter and pressure regulator. Refer to the schematic in Figure 9.

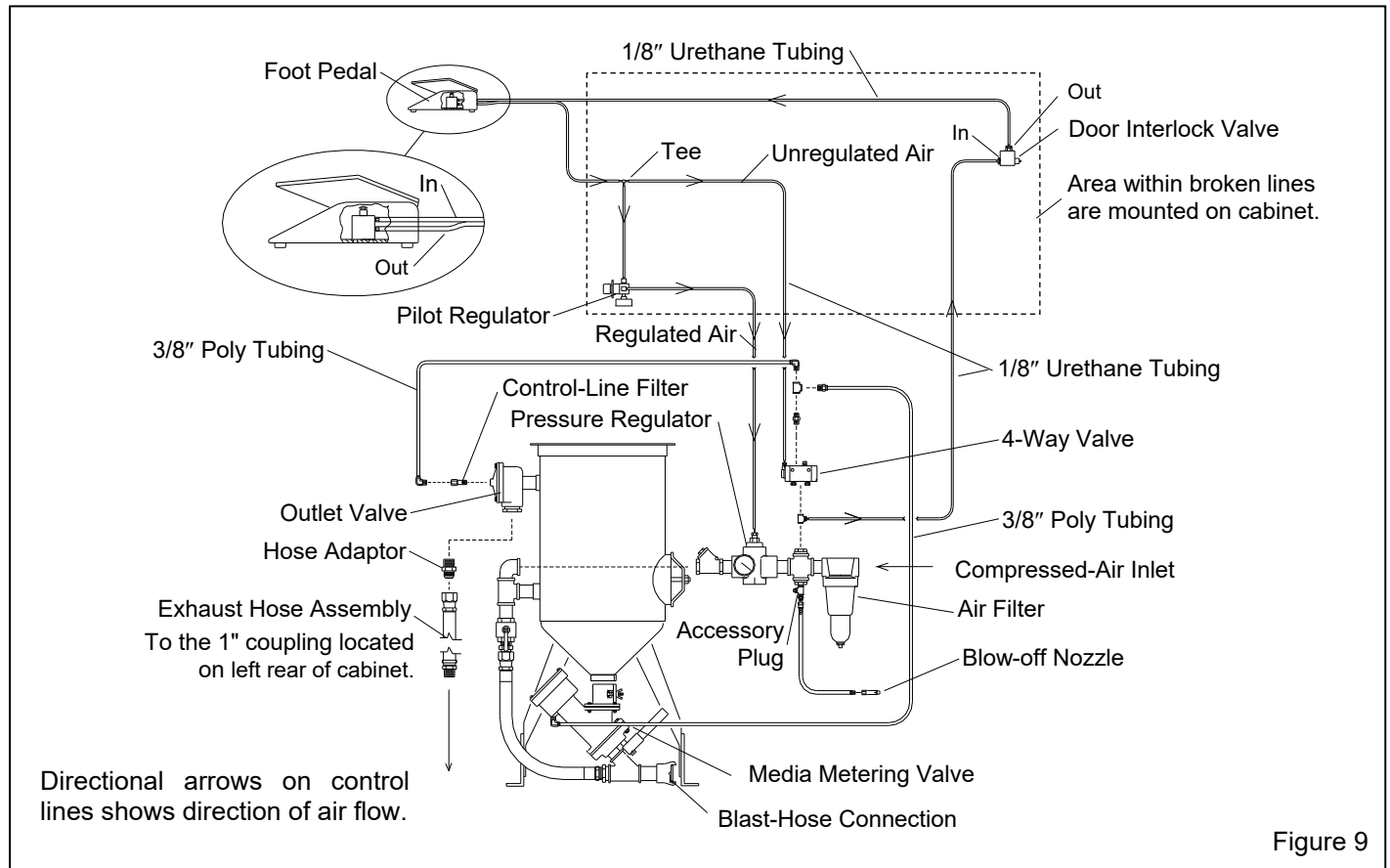

Figure 9

## 2.7 Connect Blast Hose – Figure 10

### **⚠ WARNING**

Hose disconnection while under pressure can cause serious injury or death. Use safety lock pins or safety wire to lock twist-on couplings together and prevent accidental separation, and also use safety cables to prevent hose from whipping should separation occur. Safety lock pins and safety cables are listed in *Section 9.1: Optional Accessories*.

**2.7.1** Connect the blast hose coming from the blast-hose support, located on the rear-outside cabinet wall, to the coupling at the bottom of the blast machine, as shown in Figure 10. Make sure coupling gaskets are in place and couplings are secured with safety lock pins and that the hose is secured with a safety cable.

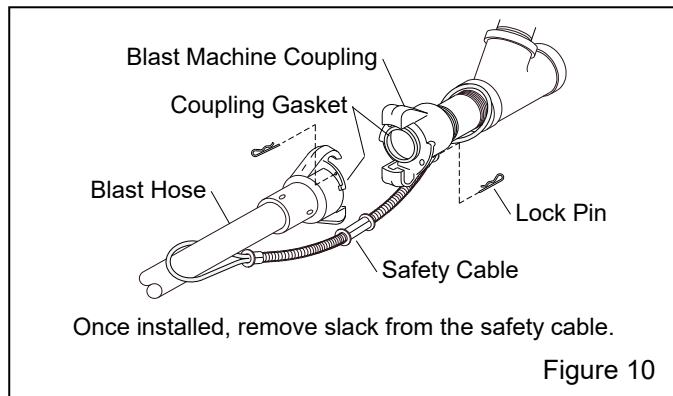

## 2.8 Connect Urethane Control Tubing

**2.8.1** Uncoil the brown 1/8" urethane control tubing. The end of each tubing is numbered 1, 2, or 3. Connect the tubing to the adaptor with the corresponding number

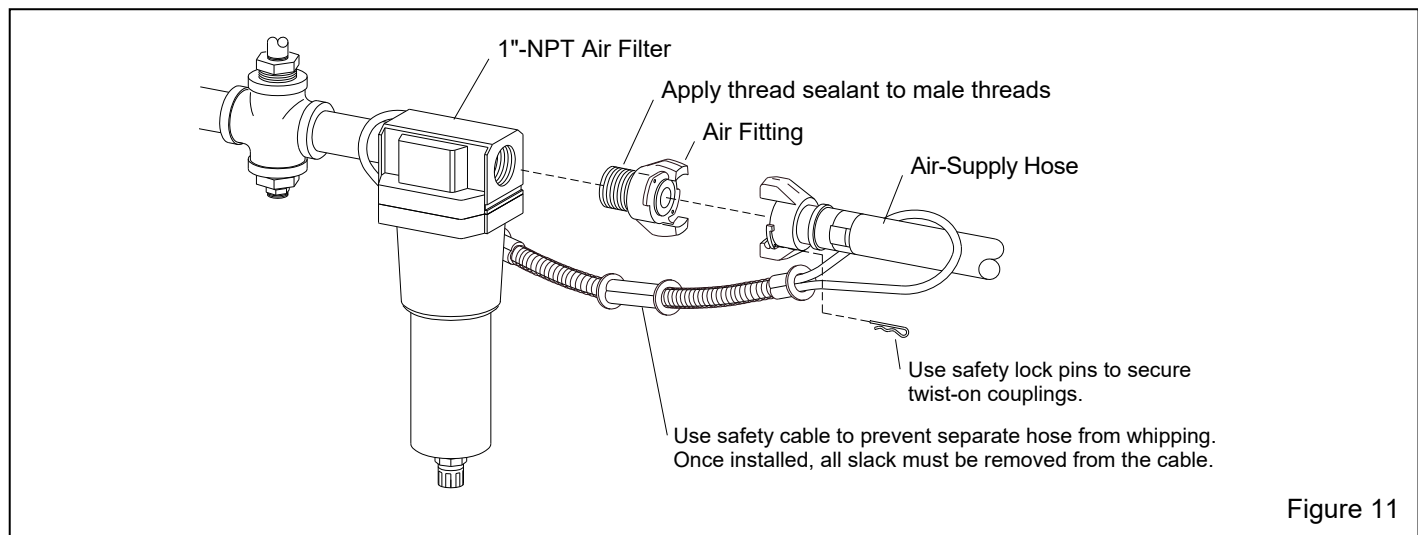

on the top of the pressure regulator, piping, and 4-way air valve. Refer to the schematic in Figure 9 to confirm the connections.

## 2.9 Connect Compressed-Air Supply Line(s) Figure 11

A separate air line is required for the dust-collector pulse. Refer to the dust-collector owner's manual.

### **⚠ WARNING**

Failure to observe the following before connecting the equipment to the compressed-air source can cause serious injury or death from the sudden release of compressed air:

- Lockout and tagout the compressed-air supply.
- Bleed the compressed-air supply line.

**2.9.1** Apply thread sealant to the male threads of an air fitting that is compatible with the air-supply hose fitting, as noted in Section 2.9.2, and install it onto the 1"-NPT air filter located at the blast machine inlet, as shown in Figure 11. Note that the style of connection shown in Figure 11 is for reference only.

### **⚠ WARNING**

Hose disconnection while under pressure can cause serious injury or death. Use safety lock pins or safety wire to lock twist-on type air-hose couplings together and prevent accidental separation, and also use safety cables to prevent hose from whipping should separation occur. Safety lock pins and safety cables are listed in *Section 9.1: Optional Accessories*.

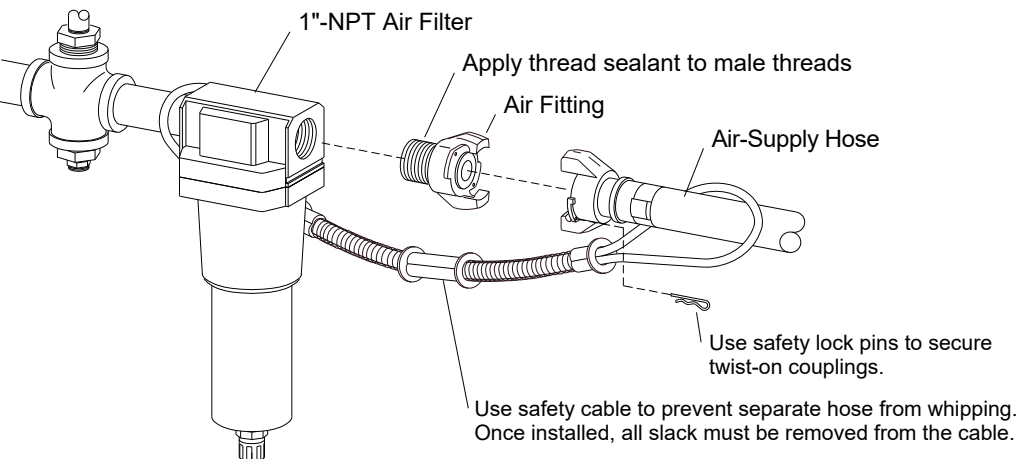

**2.9.2** Install an isolation valve at the air source to enable depressurization for service, and connect a 1" ID or larger air line from the air source to the air filter on the blast machine. A smaller diameter hose may reduce blasting efficiency.

## **⚠ WARNING**

**To avoid the risk of injury from compressed air, install an isolation valve and bleed-off valve where the air supply is tapped into the compressed-air system. This enables depressurization of the compressed-air lines before performing maintenance.**

**2.9.3** Refer to the dust-collector owner's manual and connect a compressed-air line to the pulse manifold.

### **2.10 Ground Cabinet and Dust Collector**

**2.10.1** To prevent static electricity buildup, attach an external grounded wire from an earth ground to the grounding lug on the left rear of the cabinet. Refer to the dust-collector owner's manual and connect a ground wire to the dust collector.

### **2.11 Connect Electrical Service**

## **⚠ WARNING**

**Shorting electrical components can result in serious injury or death from electrical shock and can cause equipment damage. Electrical power must be locked out and tagged out before performing any electrical work. All electrical work or any work done inside a control panel or junction box must be performed by a qualified electrician, and comply with applicable codes.**

All wiring external to the cabinet is provided by the user to comply with local electrical codes.

#### **2.11.1 Three-phase wiring**

A wiring schematic is stowed inside the control panel mounted on the back of the cabinet. After wiring is completed, keep a copy of the schematic with the manual for future reference and for electrical replacement parts.

**2.11.1.1** Refer to the wiring schematic and wire from the users disconnect to the panel and from the panel to the

dust-collector motor, per instruction on the motor data-plate.

**2.11.1.2** Check the dust-collector motor amperage on initial startup. If the motor draws excessive amperage, gradually close the dust-collector damper, located on the inlet on CDC dust collectors, and on the exhaust outlet on RPC and RPH dust collectors, until the amperage is within the specifications shown on the motor plate.

**2.11.1.3** After wiring is completed, observe the warning that follows and check the motor rotation. To check rotation, turn the On-Off switch ON and quickly turn it OFF, causing the motor to rotate slowly. Look through the slots in the motor fan housing where rotation of the fan can easily be observed. Proper rotation is indicated by the arrow on the exhaust housing; the fan should rotate toward the exhaust outlet. If it rotates in reverse, change the wires, as noted on the motor plate to reverse rotation.

## **⚠ WARNING**

**Do not look into the exhaust outlet while the paddle wheel is turning. Injury to the eye or face can occur from objects being ejected from the exhauster.**

### **2.12 Anchor Blast Machine**

**2.12.1** After all the components are in their permanent positions, anchor the machine to the floor using the holes located in the blast-machine leg pads and remove the temporary supports.

### **2.13 Set Air-Inlet Damper – Figure 12**

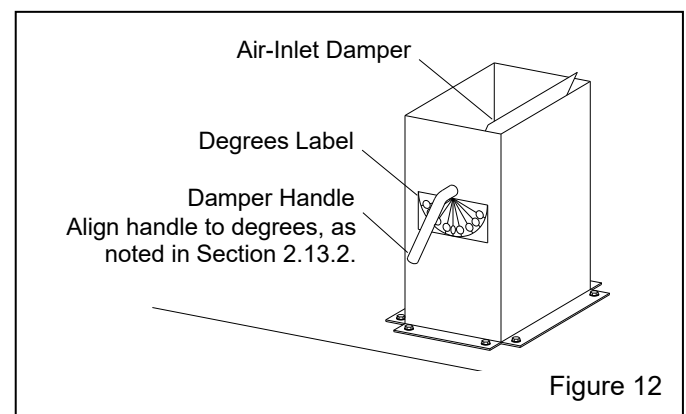

**2.13.1** The air-inlet damper is located on the top of the cabinet and must be set to match the cabinet dimensions and reclaim size. The air damper was preset prior to shipment; confirm the initial setting, as noted in paragraph 2.13.2.

**2.13.2** The label on the damper show the settings in degrees. The initial setting should align the handle, as noted.

900 reclaimer .....align handles to 30 degrees  
 1200 reclaimer ..... align handles to 0 degree (full open)  
 1800 reclaimer ..... align handles to 0 degree (full open)

**2.13.3** Loosen the lock nuts and align the damper handle as noted. When correctly positioned, tighten the lock nuts to maintain the setting. Refer to Section 5.6 for adjustment procedure.

## 2.14 Final Assembly

**2.14.1** Attach the remaining flex hose between the reclaimer outlet and dust collector inlet.

**2.14.2** Insert a short length of 3/8" tubing into the automatic drain at the bottom of the compressed-air filter, as shown in Figure 13, and place the other end into a pail. When the filter automatically drains, the water will drain into the pail.

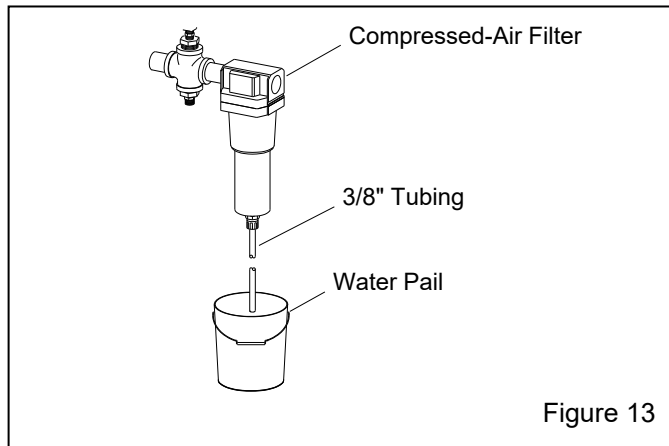

**2.14.3** Position the foot pedal on the floor at the front of the cabinet.

**2.14.4** A package of five view-window cover lenses is supplied with the cabinet. Install a cover lens, per Section 7.3. When the cover lens becomes pitted or frosted, replace it.

## 3.0 FIELD INSTALLED ACCESSORIES

Optional accessories are shown in Section 9.1

### 3.1 Aluminum Oxide (aggressive media) Kit

**3.1.1** An optional aluminum oxide kit is available factory installed or may be field installed later.

**Factory-installed kits** consist of black-rubber cabinet curtains with grommets, curtain hardware, and a boron carbide lined nozzle.

**Field-installed (or replacement factory installed) kits** consist of black-rubber cabinet curtains (refer to Section 3.2 for curtain installation), a boron carbide lined nozzle, and light-lined flex hose. If the existing flex hose is in good condition, reserve the new hose for future replacement.

## 3.2 Cabinet Curtains Installation – Figure 14

**3.2.1** Match the curtains to the corresponding wall and door as shown in Figure 14. Hook the curtains to the J-Hooks welded along the top of the front, back, and side walls. Cut openings for the hoses on the lower-left rear wall.

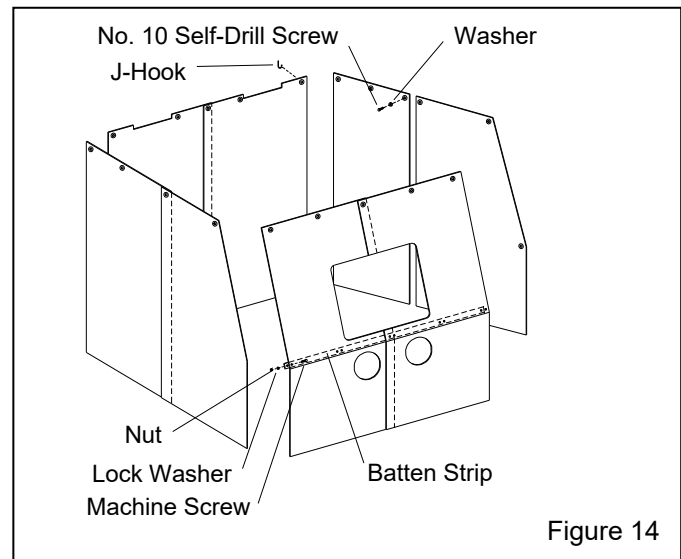

Figure 14

**3.2.2** Using protectors against the curtains and outer door, clamp the door curtains in place. The upper edges of the door curtains should be even with the outer edges of the soundproofing panel. Insert a #10 self-drilling screw with an 11/16" OD flat washer through the grommet holes. Use a screw gun with a 5/16" socket to attach the door curtains.

**3.2.3** For front walls, place the batten strip over the curtain and clamp it in position on the front slope above the break, as shown in Figure 14. Match drill .187" (3/16") diameter holes through the rubber and cabinet front at each batten hole. To install the batten, insert #10-24 x 1" round-head machine screws through the cabinet front, curtain, and batten. Install lock washers and nuts from inside the cabinet and tighten securely.

## 3.3 Manometer

The optional manometer kit is listed in Section 9.1.

**3.3.1** Consistent static pressure is necessary for precise media separation, as the reclaimers efficiency is achieved by a centrifugal balance of air flow, particle weight, and size. The manometer measures static pressure. Reclaimer static pressure is set by adjusting the dust-collector damper. Refer to Section 5.3 to adjust static pressure. Refer to Section 5.7 for instructions on using the manometer.

### 3.4 Armrest

**3.4.1** Assemble the armrest and mounting brackets, as shown in Figure 15.

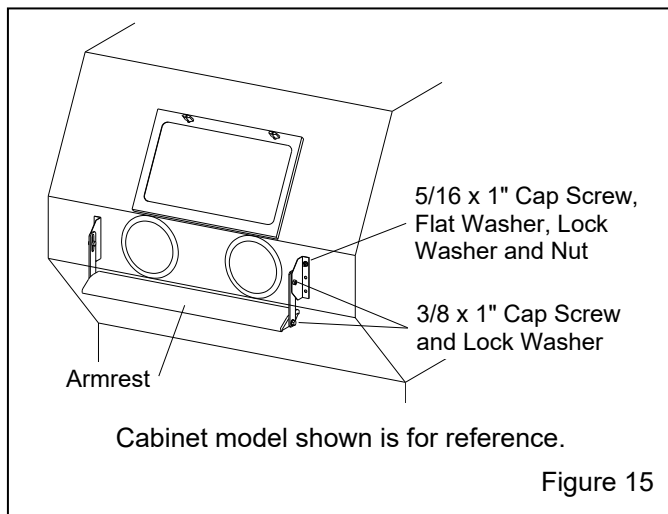

**3.4.2** Position the assembly so the armrest is about even with the bottom of the arm-port opening. Mark one hole location on the front of the cabinet at each mounting bracket.

**3.4.3** Drill a 3/8" hole at both locations and mount the armrest using 5/16-NC cap screw, washers, and nuts. Install the bolts from inside the cabinet to protect the threads from abrasion, should the armrest need to be removed later.

**3.4.4** Match drill the remaining four bracket holes and install the remaining fasteners.

**3.4.5** Loosen the fasteners on the slotted bracket and raise or lower the armrest to a comfortable position.

### 3.5 Turntable with Workcar and Track

**3.5.1** These instructions cover field installation of the 2000 lb. capacity track and workcar with turntable. If the track was ordered with the cabinet, it is partially assembled at the factory. Disregard the instructions that do not apply. Refer to Figure 16 for arrangement of the major components.

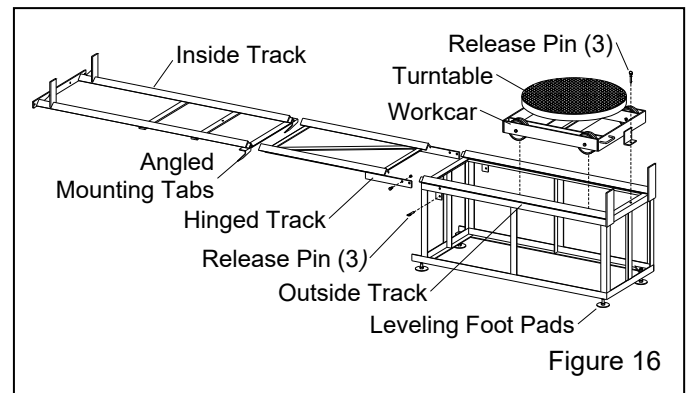

### 3.5.2 Install inside track – Figure 17

**3.5.2.1** Lay the inside track on the cabinet hoppers and above the grate, as shown in Figure 17.

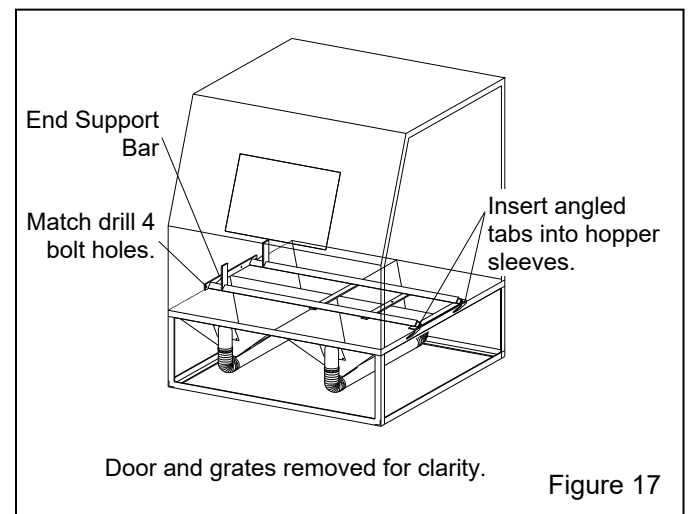

**3.5.2.2** Push the end support bar against the inside cabinet wall, opposite the door, and insert the angled tabs on the door end of the track into the two sleeves on the hopper, as shown.

**3.5.2.3** Make sure the weight of the track is evenly distributed over the hoppers and match drill through the cabinet wall, at the four hole locations in the end support bar for 3/8-NC fasteners. If necessary, mark the hole locations and remove the track for drilling.

**3.5.2.4** Secure the inside track to the cabinet with four 3/8-NC cap screw, flat washers, lock washers, and nuts provided.

### 3.5.3 Position outside track – Figure 18

**3.5.3.1** Place the outside track so it is in-line with the inside track. Space the track so the top rails (not the smaller support angles) on the hinged end are approximately 42" from the top rails on the inside track.

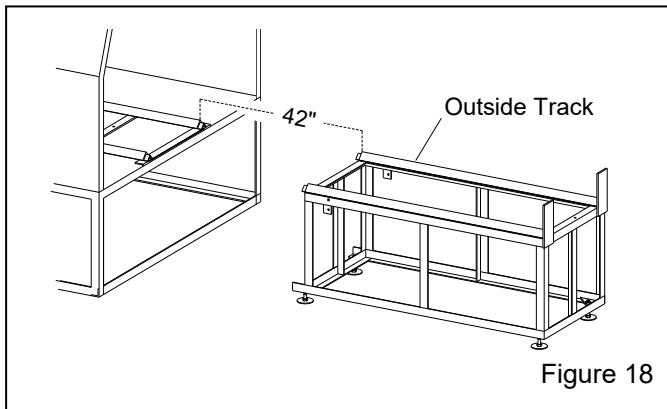

Figure 18

### 3.5.4 Attach hinged track – Figure 19

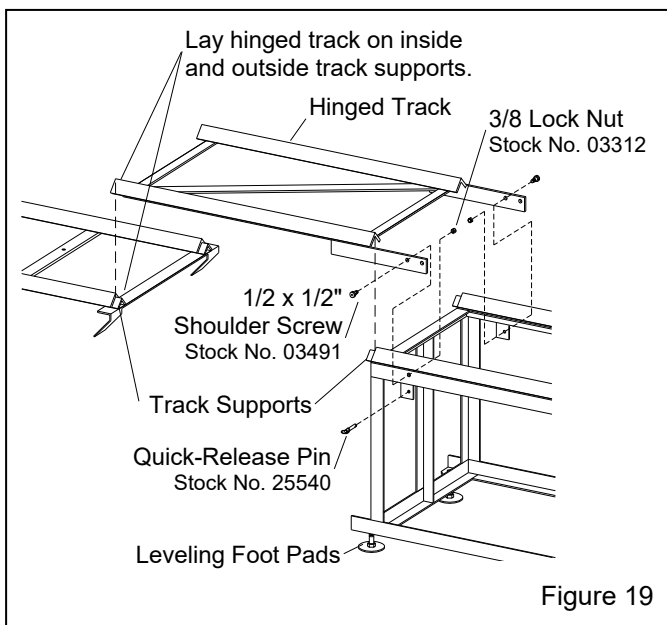

Figure 19

**3.5.4.1** With the door open, place the hinged track on the inside and outside track supports, as shown in Figure 19. Maneuver the outside track as needed to align the hinge-track bolt holes with the outside-track bolt holes, while making sure hinge track is fully resting (with no gaps) on the track supports.

**3.5.4.2** Install 1/2" shoulder screws through both hinged-track pivot bars and into the holes in the outside track. Secure with 3/8 lock nuts.

**3.5.4.3** Raise or lower the four adjustable foot pads on the outside track as needed to level it to the hinged track and inside track.

**3.5.4.4** The quick-release pin holds the hinge track when in the raised position, as shown in Figure 20.

### 3.5.5 Turntable workcar and hinge-track operations Figure 20

**3.5.5.1** Set the workcar on the outside track; the grooves in the wheels are designed to ride on the top of the track rails.

**3.5.5.2** For shipping purposes, some field-installed or replacement turntables may not be installed in the workcar. If shipped separately, slide the turntable shaft through the rubber bearing-protector, bearing collar, and bearing. When the turntable shaft is fully seated in the bearing, use a hex key to tighten the collar on the shaft.

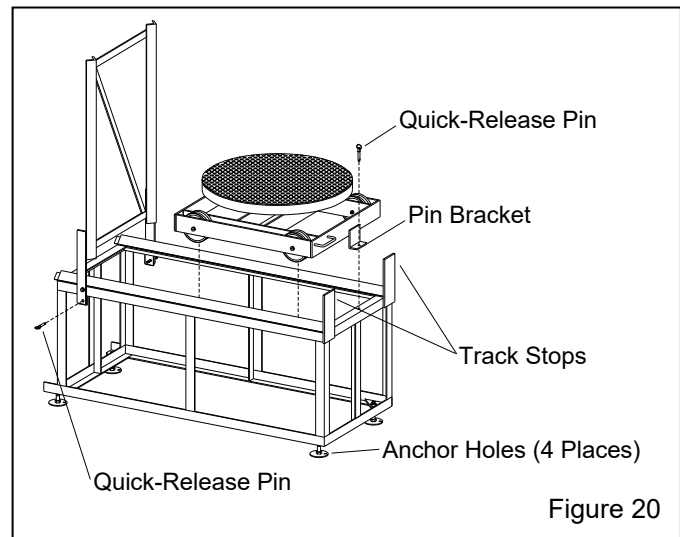

Figure 20

**3.5.5.3** Move the workcar toward the track stops until the hole in the pin bracket is aligned with the hole in the outside-track cross brace. Insert the release pin through both holes to prevent the workcar from moving. Note: A similar hole is in one of the inside-track cross braces. Inserting the pin through the workcar and inside-track hole prevents the workcar from moving when inside the cabinet.

**3.5.5.4** When certain the tracks are aligned and level, and that the workcar moves smoothly on all tracks, anchor the outside track to the floor through the holes in the foot pads.

**3.5.5.5** Raise the hinged track until the locking hole in the pivot-bars is aligned with the hole in the bracket on the bottom side of the outside hinge. Install a quick-release pin on both sides of the track to hold it vertical.

## WARNING

**Always insert pins in both sides of the hinged track to lock it upright when it is lifted vertical. The track could fall if left unlocked and cause severe injury.**

---

## 4.0 OPERATION

---

### **NOTICE**

Do not pulse new dust collectors or replacement cartridges until the cartridges are properly seasoned, as instructed in the dust-collector owner's manual. Pulsing unseasoned cartridges can decrease the efficiency of dust collectors and cause premature cartridge failure.

---

#### 4.1 Media Loading

**4.1.1 Media capacity:** Media capacity is approximately 2 cuft. Full capacity is when media is at level of the pop-up valve.

**4.1.2 Media loading:** With the exhauster OFF, add clean, dry media by pouring it into the reclaimer through the reclaimer door. **Do not pour media directly into the cabinet hopper, as overfilling may occur.** Overfilling will result in media carryover to the dust collector and possible blockage in the conveying hose. Refill only after all media has been recovered from the cabinet.

#### 4.2 Media Unloading

**4.2.1** To empty the cabinet and blast machine of media, turn the exhauster ON and blow off the cabinet interior until all media is recovered from the cabinet. Reduce pressure to 40 psi. Place an empty container, such as a bucket, on the cabinet grate. Remove nozzle and nozzle washer, close the door, close the choke valve, and press the foot pedal. Direct media flow into the container. Empty the container when full or before it is too heavy to handle, and repeat the process until the machine is empty. Return the choke valve to the full open position. Clean the nozzle holder threads and inspect the threads on the nozzle and nozzle holder before reinstalling the nozzle washer and nozzle. If complete purging of media is required, use a vacuum to clean media residue in cabinet hopper and blast machine head.

#### 4.3 Loading and Unloading Parts

**4.3.1** Load and unload parts through the door.

**4.3.2** Parts must be free of oil, water, grease, or other contaminants that will clump media or clog filters. If parts are oily or greasy, degrease and dry them prior to blasting.

---

### **⚠ WARNING**

---

Use solid fixturing to hold heavy parts in place. Do not remove lift equipment until the part is adequately supported to prevent movement. Moving heavy, unsupported parts may cause them to shift or topple, and cause severe injury. This is especially important with the use of turntables.

---

**4.3.3** When blasting small parts or objects having small pieces that could become dislodged and fall off, place an appropriately sized screen over the grate (or under the grate when frequently blasting small parts) to prevent parts from falling into the hopper. If an object should fall through the grate, stop blasting immediately and retrieve it.

**4.3.4** Close door; the door interlock system will prevent blasting if door is open.

#### 4.4 Blasting Operation

---

### **⚠ WARNING**

---

To avoid the inhalation of dust, which can cause respiratory illness from short-term ingestion or death from long-term ingestion:

- Use the blow-off nozzle to blow media off parts before opening the door.
  - After blasting, keep door closed and exhauster running until the cabinet is clear of all airborne dust.
  - Always close cabinet, reclaimer, and dust-collector doors before blasting. Keep all doors closed during blasting.
  - Always wear blast gloves.
  - Stop blasting immediately if dust leaks are detected.
- 

**4.4.1** Slowly open the air supply to the blast machine. Check for air leaks on the initial startup and periodically thereafter.

**4.4.2** Turn ON the lights and exhauster. The push-button switches located on the cabinet front performs both functions.

**4.4.3** Load parts. If parts are oily or greasy, degrease and dry them prior to blasting.

**4.4.4** Close door; the door interlock system will prevent blasting if either door is open.



4.4.5 Insert hands into blast gloves.

4.4.6 To blast, hold the nozzle holder or hose just behind the nozzle holder, point the nozzle toward the object to be blasted, and apply pressure to the foot pedal; blasting will begin almost immediately.

## **⚠ WARNING**

**Shut down the cabinet immediately if dust leaks are detected from the dust collector or cabinet. Make sure the dust-collector filter(s) are correctly seated and not worn or damaged. Prolonged breathing of any dust can result in serious lung disease or death. Short-term ingestion of toxic dust, such as lead, poses an immediate danger to health. Toxicity and health risks vary with type of media and dust generated by blasting. Identify all material being removed by blasting and obtain a safety data sheet (SDS) for the blast media.**

4.4.7 Adjust the pilot pressure regulator to the required blasting pressure, per Section 5.1. The regulator is located left of the view window. **NOTE: Pressure registers on the gauge only while blasting.**

4.4.8 When holding parts off the grate, use a solid conductive backrest to support the part. Without this assist, especially with longer blasting operations, the operator will tire easily from resisting blast pressure, and static electricity could build up in the ungrounded part and cause static shocks. Whenever possible, avoid holding small parts that require blasting into the glove.

4.4.9 If an object should fall through the grate, stop blasting immediately and retrieve it.

### 4.5 Operation and Function of the Choke Valve Figure 21

## **NOTICE**

**Do not blast with choke valve closed or partially closed. Prolonged blasting with the choke valve partially closed will accelerate wear on the metering valve.**

4.5.1 Always fully open the choke valve while blasting; open is when the handle is vertical and aligned with the piping, as shown in Figure 21.

4.5.2 Closing the choke valve while blasting lowers pressure in the pusher line from the pressure in the

vessel. Closing the valve forces media through the metering valve to clear minor blockage, such as damp media, or it is used to rapidly empty the machine to change media.

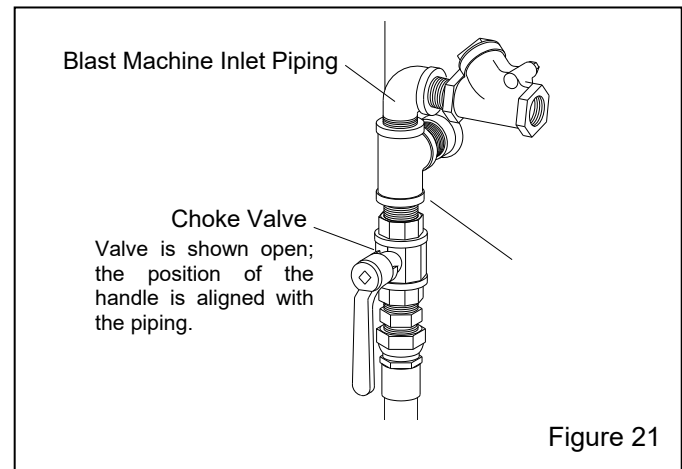

## 4.6 Blasting Technique

4.6.1 Blasting technique is similar to spray painting technique. Smooth, continuous strokes are most effective. The distance from the part affects size of blast pattern. Under normal conditions, hold the nozzle approximately 6" from the surface of the part.

## 4.7 Stop Blasting

4.7.1 To stop blasting, remove foot pressure from the top of the foot pedal.

4.7.2 The blast machine refills with media stored in the reclaimer each time the foot pedal is released. Refilling takes approximately 15 seconds.

4.7.3 Use the blow-off nozzle to blow media off parts.

4.7.4 Keep door closed and exhauster running until the cabinet is clear of all airborne dust.

4.7.5 Unload parts.

## 4.8 Shutdown

4.8.1 Shut off the air-supply valve, bleed the air-supply line, and drain the compressed-air filter and dust-collector pulse reservoir.

4.8.2 Switch OFF the lights and exhauster.

## 5.0 ADJUSTMENTS

### 5.1 Blasting Pressure (pilot regulator)

**5.1.1** The pilot pressure regulator, (located left of the view window) enables the user to adjust blasting pressure to suit the application. The suitable pressure for most purposes is about 80 psi. Lower pressures may be required on delicate substrates and will reduce media breakdown. Higher pressure may be required for difficult blasting jobs on durable substrates, but will increase media breakdown. Optimal production can only be achieved when pressure is carefully monitored.

**5.1.2** When blasting below 40 psi, first pressurize the blast machine at 40 psi and then turn the pressure to the required setting before blasting the part. If the initial pressure is below 40 psi, the pop-up valve may not seal.

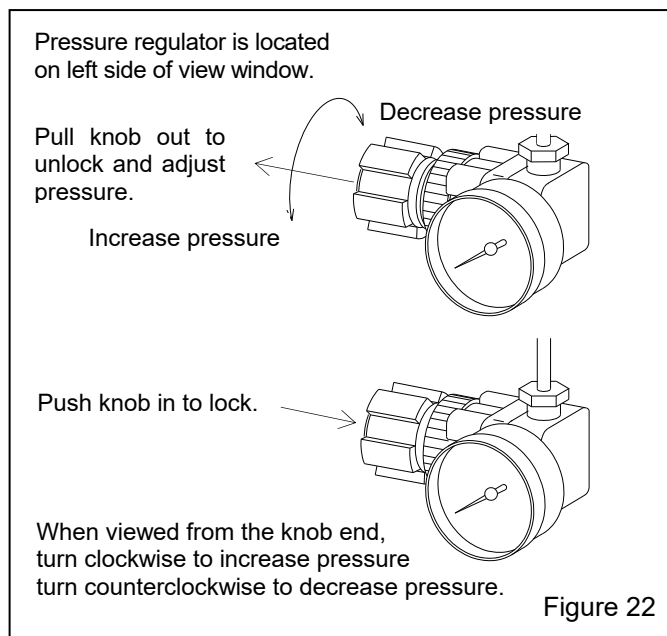

**5.1.3** Pressure registers on the gauge only while blasting. To adjust pressure, begin blasting and hold the nozzle securely with the right hand. Use the left hand to unlock the knob by pulling it out, as shown in Figure 22, Turn it clockwise to increase pressure or counterclockwise to decrease pressure. Once operating pressure is set, push the knob in to lock it and maintain the setting.

**NOTE: The operator may find it easier to adjust pressure if the knob is unlocked before blasting and when pressure is set, stop blasting to lock the knob.**

### 5.2 Media Metering (media flow) – Figure 23

These instructions and the illustration in Figure 23 are for a standard cabinet with Sentinel metering valve. Optional metering valves may function differently, but

the process is similar. Refer to the metering valve owner's manual for the operation of the valve provided.

**5.2.1** Adjust media flow using the metering valve located at the bottom of the blast machine. The valve is closed when the handle is fully to the right. To adjust, begin with the valve closed, press the foot pedal, and have someone slowly move the handle to the left to increase media flow. Allow time for the flow to stabilize before further adjusting. The valve is fully open when the handle is at the full-left position. The optimum flow rate depends on the type and size of media and blasting pressure, and can best be determined by experience. Use as little media as possible to do the job while maintaining the best cleaning rate. Generally, with the correct mixture, media can be seen as light discoloration as it exits the nozzle.

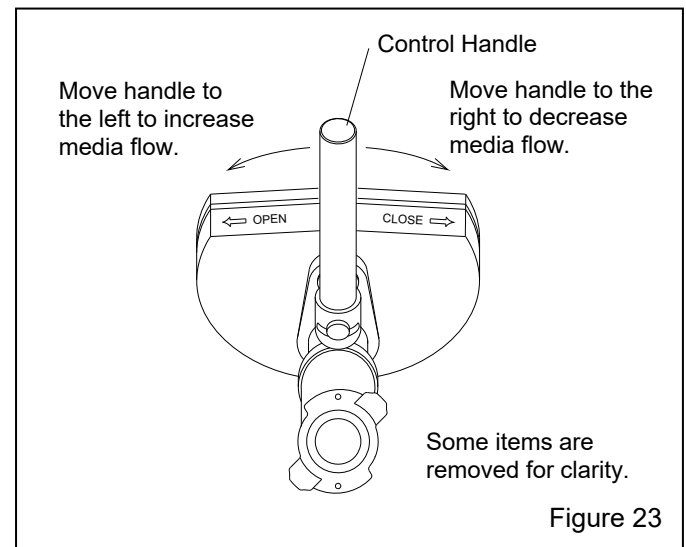

### 5.3 Reclaimer Static Pressure (dust-collector outlet damper)

**5.3.1** Correct static pressure varies with the size of reclaimer and the size, weight, and type of media.

**5.3.2** Adjust static pressure by opening (handle in line with air flow) or closing (handle perpendicular to air flow) the dust-collector damper. Refer to the dust-collector owner's manual; the damper is located on the inlet on CDC-1 Dust Collectors, and on the exhauster outlet on RPC and RPH dust collectors. If the damper is not opened far enough, the reclaimer will not remove fines, resulting in dusty media, poor visibility, and possible media blockage in the conveying hose. If the damper is opened too far, it may cause carryover (usable media carried into the dust collector) and result in excessive media consumption. Open only as far as necessary to obtain a balance of dust removal without media carryover.

**5.3.3** A manometer is useful when adjusting or monitoring static pressure. The optional manometer kit is listed in *Section 9.1: Optional Accessories*. Refer to Section 5.7 for manometer operation. The following are static-pressure starting points for given media. Static pressure may need to be lower with finer media and higher with coarser media. Run the media through several blast cycles, allowing the reclaimer to function with these settings. Inspect the media in the reclaimer and fines in the dust collector, as noted in Paragraph 5.3.2. Continue adjusting static pressure until optimum media cleaning without carryover is attained.

Glass Bead No. 4 to 7 .....	3" – 3-1/2"
Glass Bead No. 8 to 13 .....	2-1/2" – 3"
Aluminum Oxide 60 & Coarser .....	4" – 5"
Aluminum Oxide 80 & Finer .....	2-1/2" – 3"
*Steel Grit, 50-Mesh to 120-Mesh .....	6" – 7"
*Steel Shot S-170 to S-70 .....	6" – 7"

\*Refer to Section 1.11 for media limitations.

**5.3.4** If the damper has been adjusted and carryover or excessive dust in the media continues, the optional adjustable vortex cylinder may help by fine-tuning media separation. The vortex cylinder is usually required only when using 180-mesh and finer media or lightweight media. Refer to Section 5.4.

## 5.4 Externally Adjustable Vortex Cylinder

**The vortex is an option with 900 cfm reclaimers, standard with 1200 reclaimers.**

The externally adjustable vortex is an option when the cabinet is provided with a CDC-1 Dust Collector. The vortex is standard with reclaimers when the cabinet is provided from the factory with an RPC or RPH Dust Collector.

The vortex cylinder fine-tunes media separation. Before adjusting the cylinder, adjust the damper on the dust collector to increase or decrease static pressure, per Section 5.3. Once the damper is adjusted, adjust the cylinder.

**5.4.1** The vortex cylinder is located atop the reclaimer where the flex hose connects. Adjustments are made by loosening the handle's tensioning knob and moving the handle to achieve the correct setting. When the correct setting is established, tighten the locking knob to prevent movement. Start with the lever slightly to the right (about 1 o'clock, as shown in Figure 24) of the vertical position.

**5.4.2 To remove more fines:** (Too much dust in media.) Raise the cylinder by moving the lever left toward "COARSE" in 1/4" increments at the indicator

plate. Allow the media to go through several blast cycles before determining if further adjustment is needed.

**5.4.3 To remove fewer fines:** (Excessive usable media is carried to the dust collector.) Lower the vortex cylinder by moving the lever right toward "FINE" in 1/4" increments at the indicator plate. NOTE: If the cylinder is lowered too far, the reclaimer will again begin to allow usable media to be carried over and cause abnormally high static pressure.

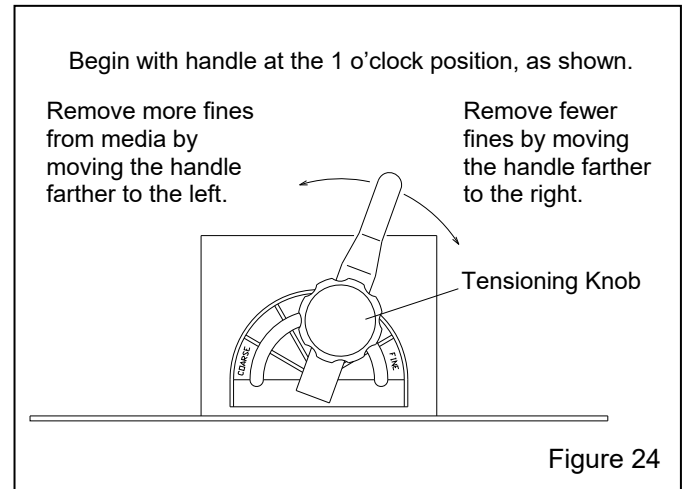

**5.4.4** When using media finer than 180-mesh, the inlet baffle of the reclaimer may need to be removed. Refer to Section 1.11.6.

## 5.5 Door Interlocks – Figure 25

### **⚠ WARNING**

**Never attempt to override the interlock system. Doing so can result in injury from unexpected blasting.**

**5.5.1** The door interlocks disable the blasting control circuit when either door is open. To enable blasting, the door-interlock switch must be engaged when the door is closed. The interlocks are set at the factory and do not normally require field adjustment unless parts are replaced. When adjustment is required, proceed as follows.

**5.5.2** Close cabinet door.

**5.5.3** Loosen the actuator bracket screws and adjusting screw nut. Move the actuator bracket up or down, and the screw sideways, to center the screw on the over-travel stop. Tighten the bracket screws.

**5.5.4** Turn the adjusting screw in or out as required to engage the switch without applying excessive pressure on it. Tighten the adjusting screw nuts.

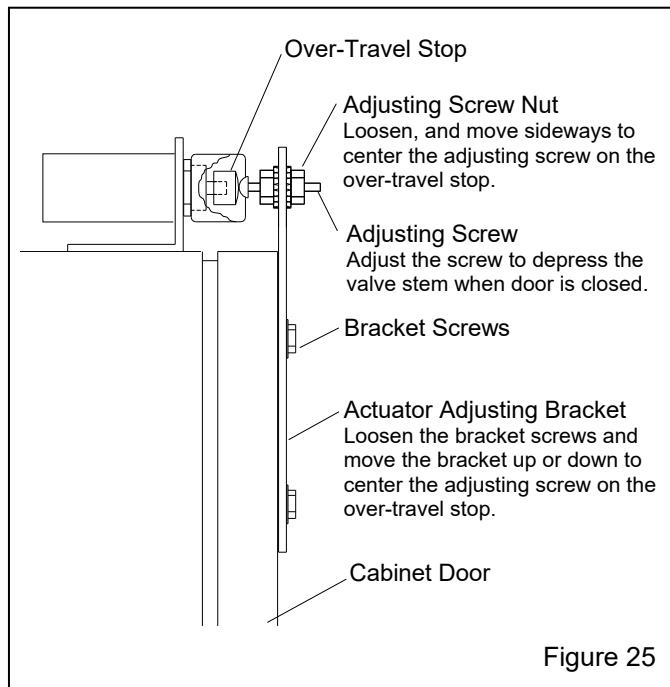

Figure 25

**5.5.5** Test the operation with the door open and then again closed. Negative pressure inside the cabinet may cause the door to flex inward. Tests should be performed with the exhauster running. Point the nozzle away from the door during the tests and open the door only enough to disengage the interlock switch. The interlocks should stop the blasting when the door is opened and permit blasting when the door is closed.

## 5.6 Cabinet Air-Inlet Damper

**5.6.1** Once the inlet is initially set, per Section 2.13, it seldom requires readjustment. The initial setting produces approximately .5" to .75" of static pressure in the cabinet enclosure. **Do not confuse cabinet static pressure with reclaimer static pressure, which is controlled by the dust-collector damper, as noted in Section 5.3. Reclaimer pressure must be set before cabinet pressure.**

**5.6.2** Using a manometer (as noted in Section 5.7 and listed in Section 9.1) is the most accurate method of monitoring and adjusting cabinet pressure. Following the instructions packed with the manometer, start the exhauster and insert the needle into a glove, and adjust pressure using the cabinet's air-inlet damper. Open the damper farther to decrease static pressure or close it farther to increase pressure.

**5.6.3** If a manometer is not available, use the gloves as an indicator. With the exhauster running, the gloves should be inflated, but not elevated off the grate.

## 5.7 Optional Manometer

These instructions show several methods of taking static pressure readings (negative pressure) on reclaimers by using a flexible-tube manometer. Use the method best suited for the application. The instructions explain the processes for taking periodic readings and show how to permanently install the manometer for taking frequent readings. A fitting should be installed when the manometer installation is permanent; refer to Paragraph 5.7.6.3. Use silicone or other sealant around the fitting to prevent leaks. The fitting should be capable of being capped when the manometer tube is removed. A cap will prevent leaks that alter the reclaimer's separation efficiency. Taking readings at different locations could produce different readings. Static pressure readings at the door are generally 0.5" to 1" lower than readings taken above the reclaimer. The readings are reference points, so readings should be taken using the same method each time the reading is taken.

**5.7.1** Refer to instructions packed with the manometer for preparing and operating the manometer.

**5.7.2** Connect one end of the 3/16" ID tubing to one of the tubing connectors (elbow) at the top of the manometer by pushing it over the barbed adaptor.

**5.7.3** Leave the needle protector on the needle and insert the needle into the other end of the tubing. The ends of the tubing must fit tight on the manometer and needle; leaks will cause inaccurate readings.

**5.7.4** Open both manometer valves (elbows), per manometer instructions.

**5.7.5** Magnets on the manometer hold it in position on the reclaimer or dust-collector body. The manometer must be vertical so the fluid is level on both sides.

**5.7.6 Needle placement:** Figure 26 shows the manometer setup for taking both periodic and frequent static-pressure readings.

**5.7.6.1 Taking readings in the flex hose:** Remove the needle protector and insert the needle into the flex hose, approximately 8" above the top of the reclaimer.

**5.7.6.2 Taking readings at the reclaimer door:** Open the reclaimer fill door, remove the needle protector, and place the needle so the tip is inside the door opening.

Carefully close the door on the needle. The side of the needle will embed into the rubber, creating an airtight seal.

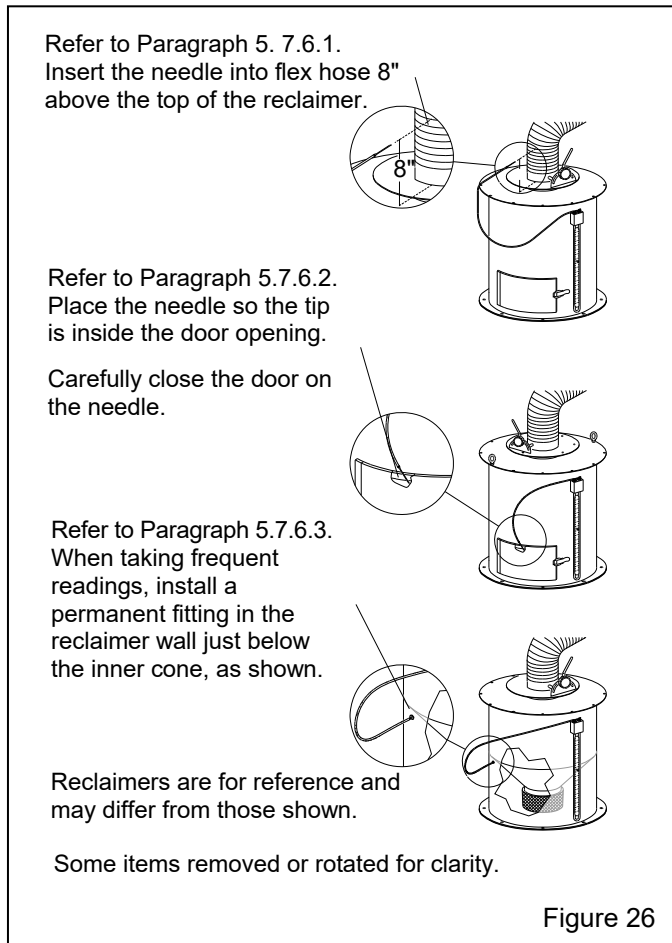

**5.7.6.3 Taking frequent readings using a permanent fitting:** A permanent fitting may be installed in the reclaimer wall, as shown in Figure 26, for taking frequent static-pressure readings. Permanent fittings must have a barb to accommodate the 3/16" ID tubing and have a means of sealing the fitting when the manometer is not in use. Use silicone sealer or other sealant to seal around the fitting to prevent leaks. The fitting should be capable of being capped when the manometer tube is removed. Sealing the fitting will prevent leaks that alter the reclaimer's separation efficiency. Air drawn into the reclaimer will cause carryover of good media to the dust collector.

**5.7.7** Adjust the slide rule to align the zero with the fluid level. Refer to the upper part of Figure 27

**5.7.8** Open cabinet door and turn the exhauster ON. The negative (static) pressure will move fluid in the tube.  
**NOTE: Readings must be taken with the cabinet door open and with the exhauster running.**

**5.7.9** To find the static pressure, add the number of inches the fluid travels up one column to the inches the fluid travels down the other column. Refer to the example in Figure 27.

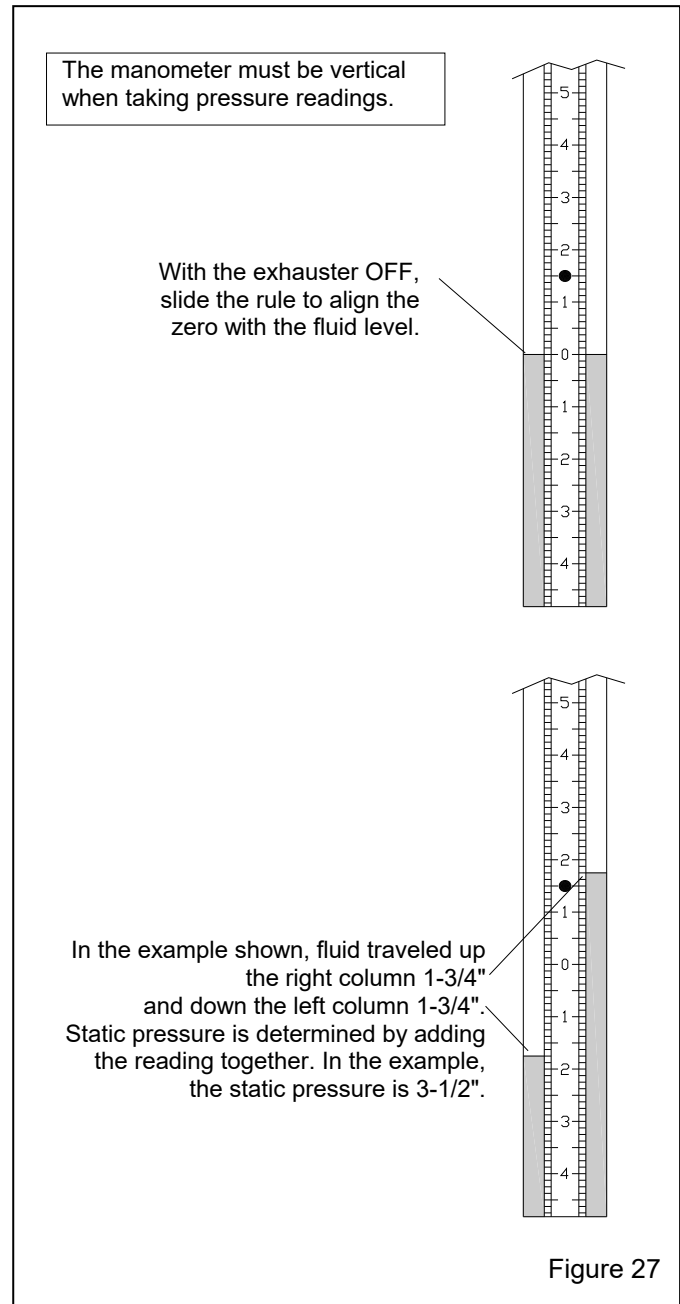

**5.7.10** After taking the readings, replace the needle protector. Close the manometer valves and store the manometer in the original container in a clean area.  
**NOTE:** If the manometer installation is permanent, the manometer may remain on the reclaimer body after the valves are closed.

---

## 6.0 PREVENTIVE MAINTENANCE

---

### WARNING

**Failure to wear an approved respirator and personal protection when servicing dust-laden areas of the cabinet and dust collector, as well as when emptying the container, can result in lung disease, serious skin or eye irritation, or other health issues. Toxicity and health risk vary with type of media and dust generated by blasting. The respirator must be approved for the type of dust generated. Identify all material being removed by blasting and obtain a safety data sheet (SDS) for the blast media.**

---

To avoid unscheduled downtime and to improve safety, establish an inspection schedule. Inspect all parts subjected to media contact, including the nozzle, blast hose, flex hose, wear plate, and all items covered in this section. Adjust frequency of inspections as needed, based on:

- **Usage:** Frequently used cabinets require more maintenance and inspections than those occasionally used.
- **Type of media:** Aggressive media wears parts faster than nonaggressive media.
- **Condition of parts being blasted:** Heavily contaminated parts require more maintenance to the cabinet's media recovery system and dust collector.
- **Friable media:** Media that rapidly breaks down require more maintenance to the cabinet media recovery system and dust collector.

### 6.1 Daily Inspection and Maintenance Before Blasting with the Air OFF

**6.1.1 Check media level:** Check media level through reclaimer door and refill as necessary, per Section 4.1.

**6.1.2 Inspect reclaimer debris screen and door gasket:** Check reclaimer debris screen for debris. The screen is accessible through the reclaimer door. With the exhauster OFF, remove the screen and empty it daily or when loading media. Empty the screen more often if part blasted causes excessive debris. Do not operate the machine without the screen in place; oversized byproduct from blasting could plug the nozzle. While the door is open, inspect the door gasket for wear or damage. Replace the gasket at the first sign of wear.

**6.1.3 Compressed-air filter:** Empty the drain pail at least once a day, and more often if needed. Moist air inhibits the flow of media. Drain the air line and receiver tank regularly. If the filter does not remove enough moisture to keep media dry and flowing, it may be necessary to install an air dryer or aftercooler in the compressed-air supply line.

**6.1.4 Inspect couplings:** Make sure couplings are secure and that lock pins and safety cables are in place.

**6.1.5 Inspect dust container:** Refer to the dust-collector owner's manual and empty dust containers. Adjust intervals based on filling rate.

### 6.2 Daily Inspection During Blasting – Have Someone Do the Following:

**6.2.1 Inspect blast hose couplings and nozzle holder:** Inspect blast-hose couplings, coupling gaskets, and nozzle holder for leaks.

---

### WARNING

**Leaks around couplings and nozzle holders indicate worn or loose-fitting parts. Nozzle holders and couplings that do not fit tightly on hose, as well as nozzles that do not fit tightly in nozzle holders, can disconnect while under pressure. Impact from objects (nozzles, couplings, hoses, or media) disconnected by pressure during operation can cause severe injury.**

---

**6.2.2 Inspect blast machine:** Check the blast machine for air leaks. If leaks are found around the pop-up valve, inspection door, or pipe fittings at the bottom of the cone, stop blasting immediately and repair or replace worn parts.

---

### NOTICE

**If leaks are allowed to continue, abrasive erosion can cause extensive or irreparable damage to the blast machine.**

---

**6.2.3 Check cabinet for dust leaks:** During operation, inspect cabinet door seals for media leaks. Dust leaking from the inlet damper or other places on the cabinet indicates saturated filter cartridge. Refer to the dust-collector owner's manual.

**6.2.4 Check dust-collector exhaust air for dust:** Dust discharge at the dust-collector outlet indicates a leaking or damaged filter cartridge. Check immediately. Note that a small amount of dust egress is normal for a short time before a new cartridge is seasoned.

**6.2.5 Drain pulse reservoir:** Refer to the dust-collector owner's manual and drain the pulse reservoir (manifold) at the end of each shift.

**6.2.6 Cartridge pulsing:** Refer to the CDC-1 Dust-Collector manual for pulsing instructions and pulse the cartridge at least every half hour of blasting and before turning OFF the exhauster. Dusty blasting conditions will require more frequent pulsing. RPC-2 and RPH-2 Dust Collectors are automatically pulsed at timed intervals.

### 6.3 Weekly Inspection and Maintenance Before Blasting with Air OFF

**6.3.1 Inspect view-window cover lens:** Inspect window cover lens and replace as needed, per Section 7.3.

**6.3.2 Inspect gloves:** Inspect gloves for wear. The first sign of deterioration may be excessive static shocks. Replace as needed, per Section 7.1.

#### 6.3.3 Inspect blast hose

---

## WARNING

---

**Worn blast hose can suddenly burst while under blast pressure. Couplings and nozzle holders will not safely grip worn hose and can blow off under pressure. Compressed air and media escaping from a burst hose, or hose whipping from a disconnected coupling or nozzle holder can cause severe injury.**

---

- Inspect blast hose for wear and soft spots by pinching it every 12 inches. Soft spots mean the hose is worn. The first sign of wear is usually along the outside radius where the hose bends just behind the nozzle holder. Replace the hose as soon as soft spots are noted.
- Make sure coupling gaskets are in good condition.
- Make sure coupling screws are fully seated in the coupling and that none are missing.
- Make sure that safety lock pins are inserted in all couplings.
- Make sure safety cables are attached at all blast-hose and air-hose connections and that all slack is removed from the cable.

**6.3.4 Inspect nozzle:** Remove the nozzle and inspect nozzle for wear. Replace the nozzle when the orifice diameter is worn 1/16" larger than original size. Before replacing the nozzle, inspect the nozzle washer; make sure it is in good condition, not worn or otherwise damaged, and in place before reattaching the nozzle.

---

## WARNING

---

**The threads on the nozzle and nozzle holder must be inspected each time the nozzle is secured to the holder. A loose-fitting nozzle may eject under pressure and cause severe injury. Check the threads for wear and make sure the nozzle holder securely holds the nozzle. The nozzle washer must also be inspected for wear. When nozzle washers are worn or missing, media can erode nozzle threads.**

---

**6.3.5 Inspect outlet valve:** Inspect outlet valve diaphragm: Remove the four cap screws and inspect the diaphragm. Replace the diaphragm if worn or cracked. Continued use with a worn diaphragm will quickly wear the valve casting.

### 6.4 Weekly Inspection During Blasting – Have Someone Do the Following:

**6.4.1 Inspect blast machine plumbing:** Inspect all external piping, hoses, valves, and couplings for air leaks. If leaks are found, repair immediately.

**6.4.2 Inspect flex hoses:** Inspect flex hoses for wear and negative pressure leaks.

### 6.5 Monthly Inspection and Maintenance

**6.5.1 Inspect reclaimer wear plate or liners:** Remove the flex hose from the reclaimer inlet and use a light to inspect the reclaimer wear plate or optional rubber reclaimer liners for wear. If the rubber is worn through to the backing metal, replace wear plate per Section 7.10 or rubber liners per Section 7.11.

**6.5.2 Inspect pop-up valve:** Check the pop-up valve's urethane coating for cracks and grooves. Replace the pop-up valve at the first sign of wear, per Section 7.8.

**6.5.3 Inspect pop-up seal:** Inspect the rubber pop-up seal and replace at the first sign of wear, drying, or cracking, per Section 7.9.

### 6.6 Dust Collector

Reverse-pulse dust collectors are covered in a separate manual. Refer to Section 1.1.1.

---

## 7.0 SERVICE MAINTENANCE

**⚠ WARNING**

Prior to doing any maintenance or opening the dust collector, the employer must meet required OSHA standards, including but not limited to 29CFR 1910 for:

- Appropriate Respirator
- Protective Clothing
- Toxic and Hazardous Substances
- Fall Protection
- Lockout and Tagout

All dust is hazardous to breath; toxicity and health risk vary with type of dust generated by blasting. Prolonged exposure to any dust can result in serious lung disease and death. Short-term exposure to toxic materials, such as lead dust or dust from other heavy metals and corrosives, can cause serious injury or death. Identify all material that is being removed by blasting and obtain a safety data sheet (SDS) for the blast media. Waste dust in the collector can cause serious injury or death through inhalation, absorption, or ingestion. The employer shall meet all OSHA requirements, including but not limited to those for confined space, combustible dust, fall protection, hazard communication, and lockout and tagout procedure for electrical and pneumatic supply.

## 7.1 Gloves

7.1.1 Special static-dissipating gloves are provided for operator comfort. Gloves need to be replaced periodically as they wear. The first sign of deterioration may be excessive static shocks.

7.1.2 **Band-clamp type:** Band-clamp type gloves are held in place by metal band clamps on the inside of the cabinet. To replace, loosen the clamps with a screwdriver, replace the gloves, and tighten the clamps.

7.1.3 **Quick-change type, clampless installation:** Quick-change gloves are held in place using spring rings sewn into the attachment end of the glove. To install, insert the glove into the arm port so that one spring is on the inside of the port and the other is on the outside, sandwiching the arm port between both spring rings.

## 7.2 Blast Hose and Nozzle – Figure 28

7.2.1 To remove old hose, disconnect hose from blast machine and remove nozzle holder or coupling, and then pull the hose through the hose support. Install new hose and couplings in reverse order.

7.2.2 When replacing blast hose, make sure the hose is square cut and that it is fully inserted into the nozzle holder and coupling until it sits tightly against the shoulder in the holder and coupling, as shown in Figure 28. Make sure correctly sized screws are used to secure the nozzle holder and blast-hose coupling. Screws should not penetrate the inside of the blast hose.

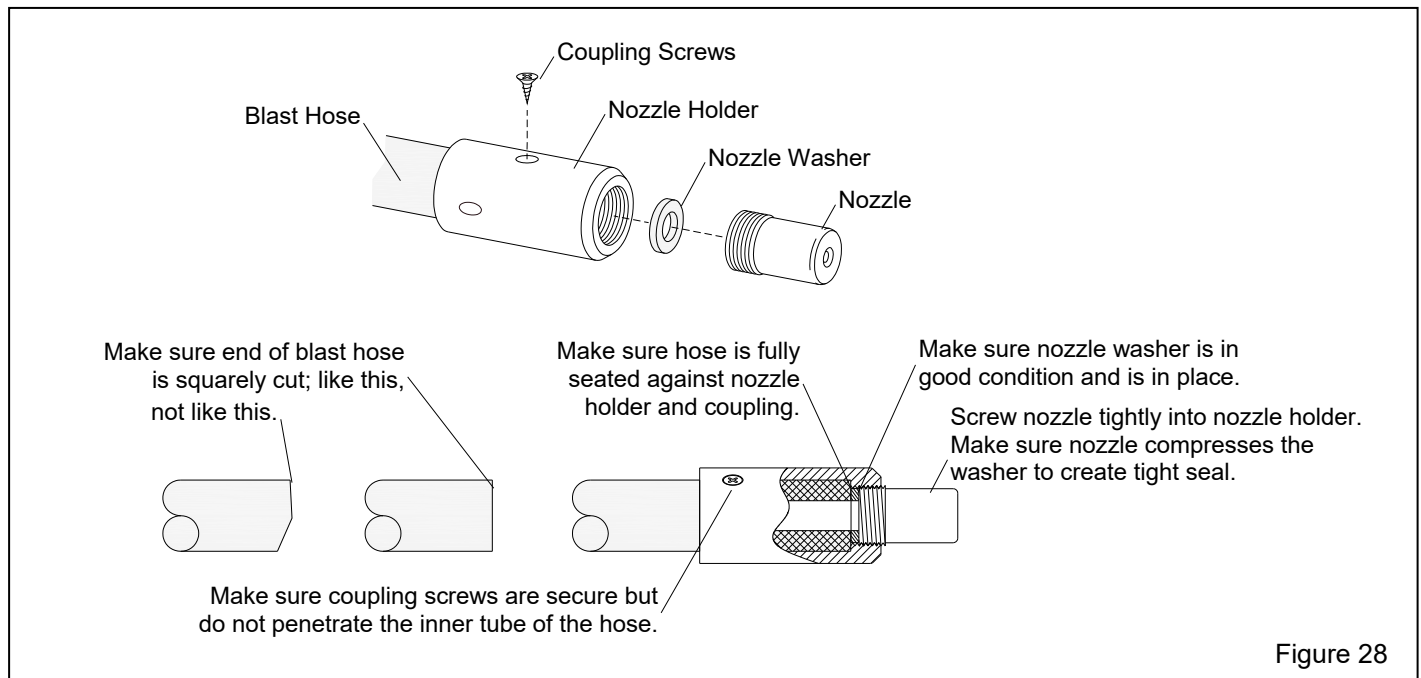

Figure 28



**7.2.3** Replace the nozzle when its orifice (the smallest inside diameter) has increased by 1/16" or sooner if blast pressure noticeably diminishes. Make sure the nozzle washer is in good condition and in place before screwing the nozzle into the nozzle holder. Make sure the nozzle is screwed tightly into the nozzle holder; if nozzle is not tight against the nozzle washer, thread erosion will occur and nozzle will fuse to nozzle holder.

### 7.3 View-Window Cover Lens

**7.3.1** Rapid frosting of the view window can be avoided by directing ricocheting media away from the window and by installing a cover lens on the inside surface of the window. Using cover lenses prolongs the life of the view window.

**7.3.2** The best way to install a cover lens is to remove the window from the cabinet. If, for any reason, it is not practical to remove the window, the lens may be applied with the window glass in place.

**7.3.3** To install a cover lens, carefully remove the adhesive backing making sure the adhesive remains on the lens and apply the lens to the clean, dry, inner surface of the view window. When the cover lens becomes pitted or frosted, replace it.

### 7.4 View-Window Replacement

## **⚠ WARNING**

**Do not use plate glass for replacement view windows. Plate glass shatters on impact and can cause severe injury. Use only genuine ZERO® laminated replacement glass.**

**7.4.1** Remove the two window-frame nuts located on the upper edge of the window frame and swing the window frame open. If the frame is to remain open for cleaning or other reasons, remove it, per Section 7.6.

**7.4.2** Remove the old window.

**7.4.3** Inspect the window-frame gaskets on both the window frame and on the cabinet. If either gasket is damaged, replace it, per section 7.5.

**7.4.4** Install view-window cover lens, per Section 7.3.

**7.4.5** Set the new window (cover lens down) squarely over the window opening, making sure that all edges of the window are centered and overlapping the window gasket, and that the window is resting on the window support tabs.

**7.4.6** Swing the window frame into place and tighten the frame nuts.

### 7.5 Window-Gasket Replacement – Figure 29

**7.5.1** Inspect the gaskets when changing the view window. Replace the window-frame gasket and cabinet window-opening gasket at the first sign of media leakage around the view window, or if gaskets are worn or otherwise damaged.

**7.5.2** Remove the window and window frame, per Section 7.6.

**7.5.3** Remove all the old gasket material and clean the surfaces of the cabinet and window frame.

**7.5.4** Peel a short section of adhesive backing from the 5/16"-thick strip gasket and adhere the gasket to the center of the top edge of the window opening, as shown in Figure 29. Peel additional backing as needed and work the strip around the radius of each corner, pressing it firmly to bond. Trim the gasket to fit and compress the ends to seal.

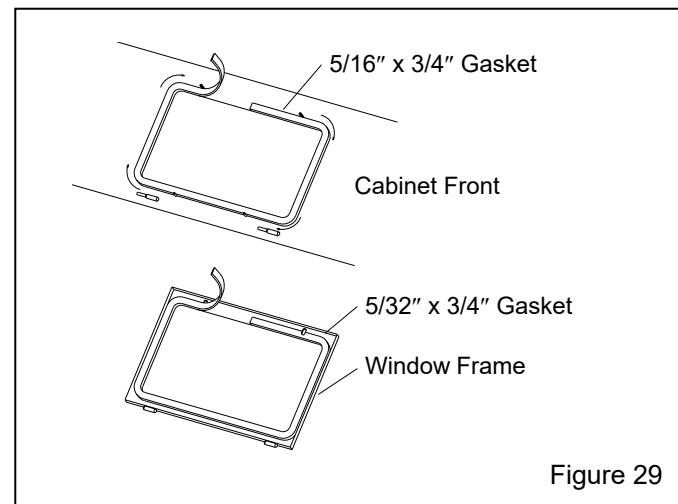

**7.5.5** Using 5/32"-thick strip gasket, repeat the process on the underside of the window frame.

**7.5.6** Trim around window-frame bolt slots, as needed.

### 7.6 Window-Frame Removal – Figure 30

**7.6.1** Remove the two window-frame nuts located on the upper edge of the window frame and swing the window frame open.

**7.6.2** Remove the window to prevent breakage.

**7.6.3** Pivot the window frame up or down until tension is off the frame hinges.

**7.6.4** Slide the frame to the right to remove it. The hinges separate, as shown in Figure 30.

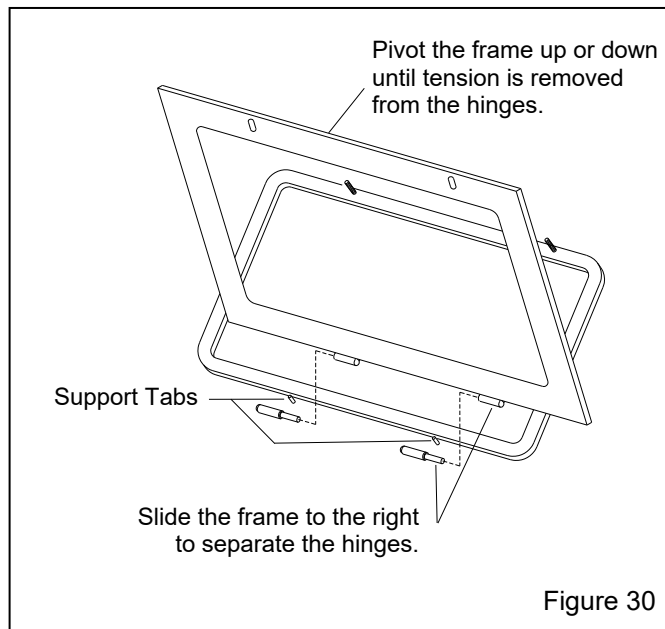

**7.6.5** Replace the frame in reverse order. Slide the frame as necessary to align the top bolt holes with the bolts.

**7.6.6** Set the window squarely over the window opening. Make sure that all edges of the window are centered, overlapping the window gasket, and that the window is resting on the window support tabs.

**7.6.7** Swing the window frame into place and tighten the frame nuts.

## 7.7 LED Light Assembly

Follow the steps for both light assemblies

### **⚠ WARNING**

**Use an approved stepladder when servicing the light assembly. Do not climb on top of the cabinet. The cabinet top will not support the weight of a person. Failure can result in injury and property damage.**

#### 7.7.1 Remove light-mount cover

**7.7.1.1** Turn OFF electrical power.

**7.7.1.2** Remove the four nuts and washers that attach the light-mount cover to the cabinet and remove the cover, as shown in Figure 31.

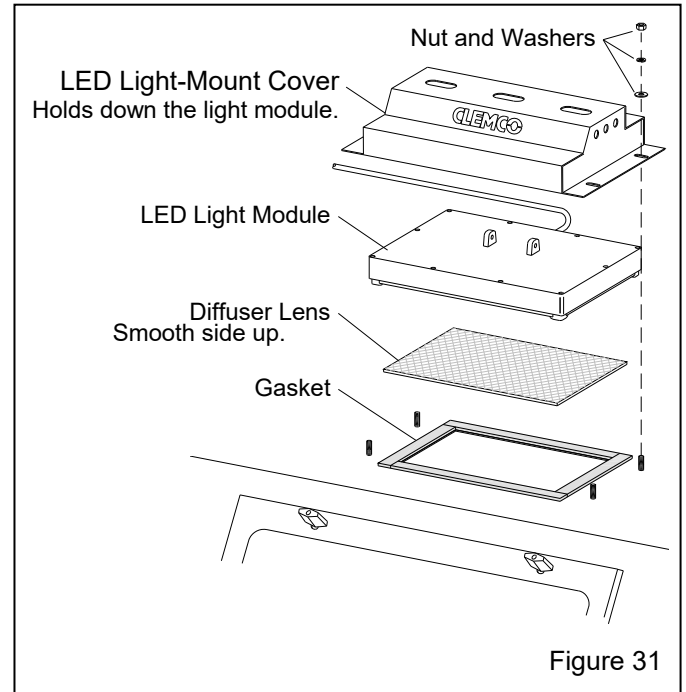

#### 7.7.2 Gasket replacement

**7.7.2.1** Remove the four nuts and washers that attach the light-mount cover to the cabinet and remove the cover, as noted in Section 7.7.1. Move the light module off the diffuser lens and remove the lens.

**7.7.2.2** Remove all the old gasket material and clean the surface of the cabinet.

**7.7.2.3** Lay a section of strip gasket along the edge of the opening and cut to length allowing 3/4" overlap on each end. Peel a short section of adhesive backing and adhere the strip gasket to the top edge of the light opening, as shown in Figure 31. Press the gasket to bond. Repeat the process for each side, compressing the ends to seal.

#### 7.7.3 Diffuser lens replacement

**7.7.3.1** Remove the four nuts and washers that attach the light-mount cover to the cabinet and remove the cover, as noted in Section 7.7.1. Move the light module off the diffuser lens and remove the lens. Inspect the gasket and replace it, per Section 7.7.2, if it is compressed or otherwise damaged, before centering the new diffuser (smooth side up) over the gasket.

**7.7.3.2** Set the light module on the diffuser and reattach the cover.

### 7.7.4 LED module replacement

**7.7.4.1** Turn OFF electrical power and perform lockout and tagout procedure to power supply.

**7.7.4.2** Remove the cover mount, per Section 7.7.1

**7.7.4.3** Remove the junction box cover and make note of the color code before disconnecting the module wires. Current connections are as follows:

- Brown wire ..... Hot
- Blue wire ..... Neutral
- Yellow w/green stripe ..... Ground

If color coding is different from that shown above, make note of the color code before disconnecting the wires.

**7.7.4.4** Loosen the strain-relief compression nut and remove the cord from the junction box.

**7.7.4.5** Place the new module in position on the cabinet and route the cord through the strain relief and into the junction box.

**7.7.4.6** Cut the cord to length and wire as follows:

- Brown wire ..... Hot
- Blue wire ..... Neutral
- Yellow w/green stripe ..... Ground

**7.7.4.7** Apply power to test the light(s).

**7.7.4.8** Tighten the strain-relief compression nut, set the light module on the diffuser, and reattach the cover.

### 7.8 Replacing Pop-Up Valve

**7.8.1** Empty the machine of media, as described in Section 4.2.

## **⚠ WARNING**

**Failure to observe the following procedure before performing any maintenance can cause serious injury or death from the sudden release of compressed air.**

- **Depressurize the blast machine.**
- **Lockout and tagout the compressed-air supply.**
- **Bleed the air-supply line to the blast machine.**

**7.8.2** Depressurize the blast machine, and lockout and tagout the compressed-air supply.

**7.8.3** To gain access to the pop-up valve, remove the inspection door assembly as follows:

1. Loosen the inspection-door clamp nut enough to slide the clamp bolt from behind the bolt bracket; then remove the clamp, bolt, and nut, as an assembly, as shown in Figure 32.

2. Push the inspection-door plate into the blast machine and rotate it so it can be removed through the inspection door. If the plate is stuck to the inspection-hole ring, rap the door with a rubber mallet or similar tool to loosen it. Remove the door gasket if it is cracked, dry, or otherwise damaged.

**7.8.4** If the gasket requires replacement, use rubber-based glue to adhere it to the inspection-door plate. Allow the adhesive to cure before bolting the plate onto the machine.

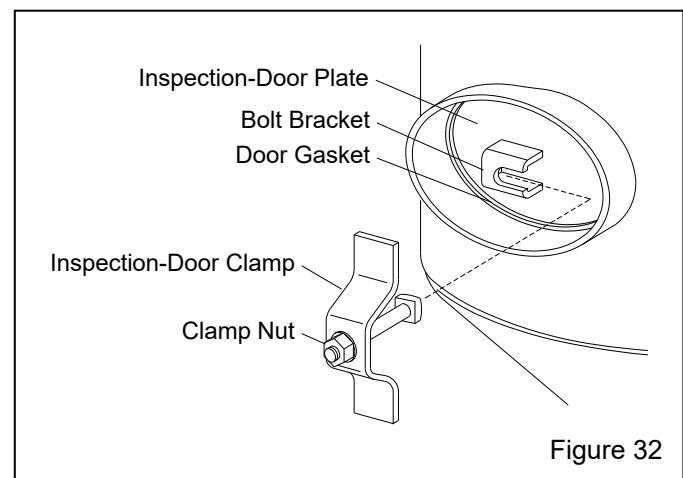

Figure 32

**7.8.5** Use a short pipe wrench to unscrew the pop-up valve guide from the elbow by turning it counterclockwise, as shown in Figure 33. Remove the pop-up valve and guide from the machine.

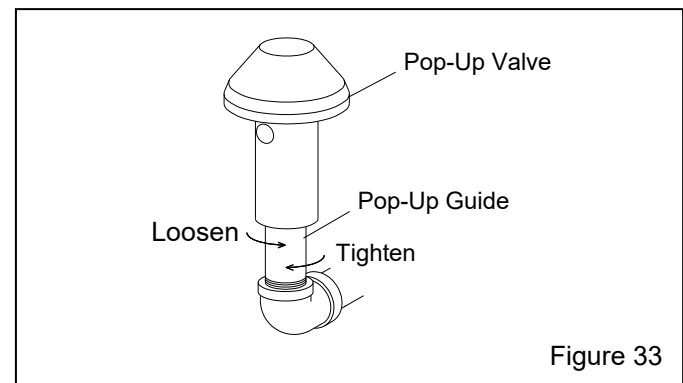

Figure 33

**7.8.6** Slide the new pop-up valve over the guide and then screw the guide (with the pop-up valve on it) into position inside the machine. Tighten the guide wrench-

snug, but not wrench-tight. Overtightening the guide will make it difficult to remove next time the pop-up valve needs replacement.

**7.8.7** Bolt the plate onto the machine and tighten to approximately 55 ft lbs. Pressurize the vessel and check for air leaks. If leaks are noted, depressurize the machine and tighten the clamp nut.

## 7.9 Replacing Pop-Up Valve Seal – Figure 34

**7.9.1** The easiest method to replace the rubber pop-up seal is through the reclaimer access door. If for any reason replacement cannot be made through the reclaimer, observe the warning in Section 7.8, empty media from the machine, and bleed the air-supply line. Remove the inspection door assembly, as noted in Section 7.8.3, and work through the opening.

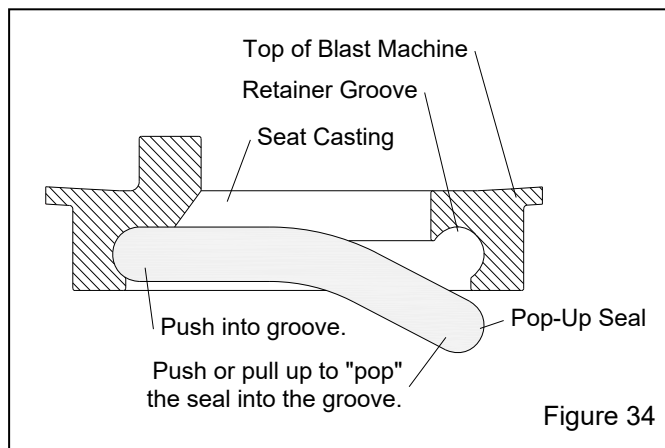

**7.9.2** Remove the old seal by using a finger, screwdriver, or similar object to work the seal out of the retainer groove.

**7.9.3** Push the new seal all the way through the port and then fit it into the groove. For the last few inches, pull up on the seal and allow it to "pop" into position.

## 7.10 Replacing Reclaimer Wear Plate – Figure 35

### Reclaimer with bolt-on, removable top

Depending on conditions such as height and accessibility, it may be easier to replace the wear plate if the reclaimer is removed from the blast machine. Make sure enough 13089 - 2" adhesive-backed gasket is available to replace compressed or damaged gaskets on the reclaimer upper flange (and lower, blast machine flange if the reclaimer is removed from the blast machine).

- 900 cfm requires 7 ft for each flange.
- 1200 cfm requires 7 ft for the lower flange and 8 ft for the upper flange.

## **⚠ WARNING**

**BNP reclaimers weigh between 150 lbs and 250 lbs, depending on the size. When installing or removing the reclaimer, it must be adequately supported and secured to appropriate lift equipment. Failure to secure and use proper lift device can result in injury or death. When using a ladder to service the reclaimer, make sure it is approved for the application and that appropriate fall protection is used. Failure to use appropriate ladder and fall protection can result in injury.**

**7.10.1** Remove the flex hose from the reclaimer inlet.

**7.10.2** Unbolt the reclaimer top and then remove the top, the inlet pipe adaptor, adaptor gasket, and old wear plate. The wear plate is held in place by screws attached from the outside of the reclaimer. Remove the screws and pull out the wear plate.

**7.10.3** Remove remnants of old caulk that will prevent the new wear plate from seating against the reclaimer wall or top.

**7.10.4** Angle the new wear plate into the reclaimer inlet and position it so the straight end is flush with the inlet. Use locking pliers, clamps, or other means where needed to pry the wear plate against the side of the inlet and inner wall. Make sure the leading edge of the wear plate is aligned with the reclaimer inlet and that the top edge is even with the top of the reclaimer.

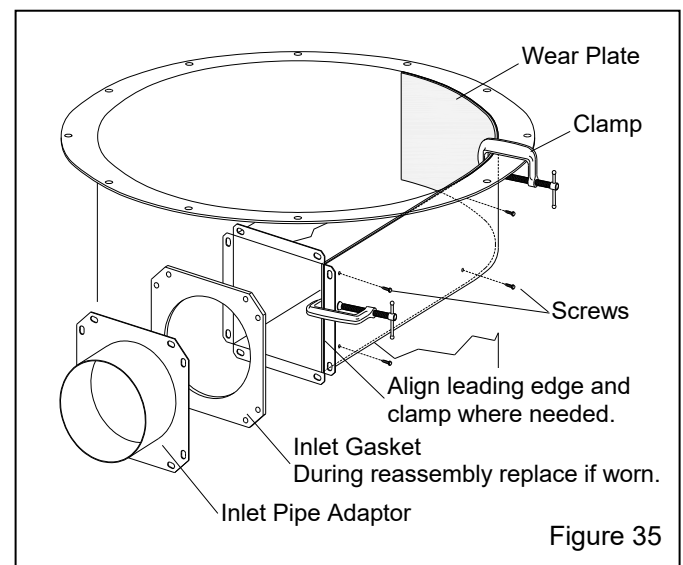

**7.10.5** New self-drilling sheet-metal screws are provided with the wear plate; match drill through each old screw hole into the wear plate to secure. Rearrange

the clamp(s) as needed to press the wear plate against the reclaimer wall when installing.

**7.10.6** Replace the upper flange gasket as needed and reattach the reclaimer top.

**7.10.7** To avoid rapid wear, apply RTV caulk to fill gaps at the seams on the top and bottom of the wear plate.

**7.10.8** Replace the lower flange gasket as needed and reattach the reclaimer to the blast machine.

**7.10.9** Attach the inlet pipe adaptor, replacing the gasket if worn, compressed, or otherwise damaged.

**7.10.10** Reconnect the flex hose.

**7.10.11** Allow time for the caulking to cure before putting the reclaimer into service.

### 7.11 Replacing or Field Installing Optional Reclaimer Rubber Liners – Figure 36

The reclaimer must be designed to accept liners and have a removable top, as shown in Figure 36. **NOTE: The following instructions are to replace existing liners or field installing new liners into current modular-style 900 cfm and 1200 cfm reclaimers only.**

#### Installation Notes

Make sure enough 2" adhesive-backed gasket (stock no. 13089) is available to replace the compressed or damaged gasket on the reclaimer/blast machine flange.

- 900 cfm requires 7 ft.
- 1200 cfm requires 7 ft.

The inner cone and cone ring are glued in place. Make sure a multi-purpose contact adhesive, such as 3M® no. 10 neoprene contact adhesive or equal, is available.

It is easier to replace or install liners if the reclaimer is removed from the blast machine.

## WARNING

**BNP reclaimers weigh between 150 lbs and 250 lbs, depending on the size. When installing or removing the reclaimer it must be adequately supported and secured to appropriate lift equipment. Failure to secure and use proper lift device can result in injury or death. When using a ladder to service the reclaimer make sure it is approved for the application and that appropriate fall protection is used. Failure to use appropriate ladder and fall protection can result in injury.**

**7.11.1** Remove the flex hoses from the reclaimer inlet and outlet.

**7.11.2** Remove the reclaimer from the blast machine.

**7.11.3** Set the reclaimer top-side-up on a clean, flat, and level surface.

**7.11.4** Remove the reclaimer inlet-pipe adaptor.

**7.11.5** Remove the bolts and nuts securing the reclaimer top, and then remove the top. (and top liner if the reclaimer is currently lined).

**7.11.6** If the reclaimer is currently unlined, proceed to the installation note preceding Paragraph 7.11.13.

**7.11.7** Remove the top liner and cylinder liner: Grind the tack welds from the bottom of the cylinder liner that secure the liner to the tube, and then slide the cylinder liner and top liner off the inner tube.

**7.11.8** Remove the nuts and washers located along the right side of the inlet and remove the inlet baffle through the top of the reclaimer.

**7.11.9** Remove the screws holding the inlet-side liner and inlet-top liner and remove both liners from the reclaimer inlet.

**7.11.10** The wall liner is held in place with self-drilling screws; from the outside of the reclaimer, remove the screws and lift the wall liner from the top of the reclaimer.

**7.11.11** Inner cone liners and cone-ring liners are glued onto the inner cone. Pull off the liners to remove them.

**7.11.12** Remove old caulking and adhesive from the weldment.

**Installation Notes:** The numbers in parentheses (-) shown in Figure 36 and in the following applicable paragraphs show the recommended order of installation. When installing the liners, make sure that seams are aligned. The final assembly must be smooth and free of protrusions, edges, and gaps. Any edges will disrupt the air flow, cause wear and affect the reclaimer's media cleaning efficiency.

**7.11.13 (1st)** Place the cone-ring liner on the inside of the cone ring; check fit and trim if needed. Refer to the instructions provided with the adhesive; some adhesives require it to be applied to both contact surfaces. Apply a multi-purpose contact adhesive, such as 3M® no. 10 neoprene contact adhesive or equal, to the fabric side of the liner and install the liner. Smooth out the liner to eliminate air pockets.

**7.11.14 (2nd)** Place the cone liner in the cone with the fabric side down, and check fit and trim if necessary. Apply medium-set contact cement to the fabric side, and install the cone liner. Smooth out the liner to eliminate air pockets.

**7.11.15 (3rd)** Place the inlet-side liner (rubber side out) against the side of the inlet housing; center the side liner and align the front edge of the liner with the front of the housing. Temporarily clamp the side liner in place.

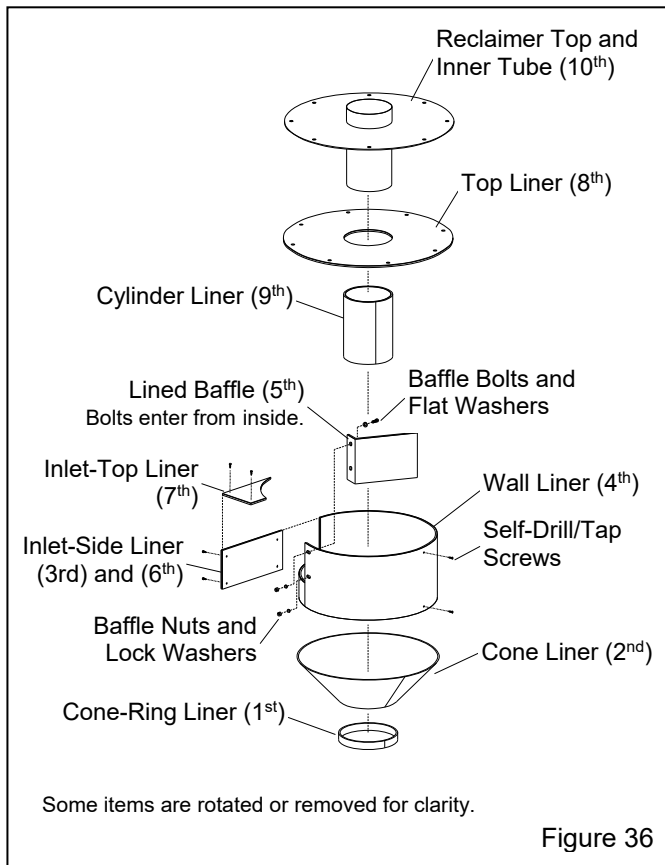

**7.11.16 (4th)** Align the wall-liner cutout with the reclaimer inlet housing and lower the liner into the reclaimer. Temporarily insert the baffle bolts through the liner and reclaimer holes to position that side of the wall liner. Clamp the wall liner in place, making adjustments to make sure it is flush with the top of the reclaimer body and that the inlet-side liner is aligned with the side-liner cutout. Reposition the inlet-side liner as needed.

While pushing or clamping the liner against the weldment, secure the wall liner with self-drilling screws at each existing hole location. **NOTE: To field install a new, first-time wall liner, use self-drilling screws to secure it at the seam and an inch or two from the top and bottom at each quadrant.** Remove the clamps after the liner is secured.

**7.11.17 (5th)** Remove the temporary baffle bolts and install the inlet baffle by inserting bolts and flat washers

from the inside of the reclaimer and attach lock washers and nuts from the outside, leaving the baffle slightly loose.

**7.11.18** Apply silicone caulking on seams between the cone ring and cone liner, to the seams on the cone ring and cone, between the cone liner and wall liner, and the seam on the wall liner. Wipe caulking to even with the liners. Voids will cause premature wear.

## NOTICE

**All seams between each liner must be sealed, and all seams between the liners and reclaimer weldment must be sealed. Voids will cause premature wear.**

**7.11.19 (6th)** Use self-drilling screws to secure the inlet-side liner to the side of the inlet housing. **NOTE:** To field install new, first-time inlet-side liners, use self-drilling screws at each liner corner to secure. Remove the clamps after the liner is secured.

**7.11.20 (7th)** Align the front edge of the inlet-top liner to the front of the inlet housing and use self-drilling screws to secure. **NOTE:** To field install new, first-time inlet-top liners, after clamping the liners, use self-drilling screws at each liner corner to secure. Remove the clamps after the liner is secured.

**7.11.21 (8th)** Slide the top liner onto the inner tube and align the holes in the liner with those in the top. Note that the holes around the inlet are spaced differently from the others. Temporarily install a couple of bolts to keep it in alignment.

**7.11.22 (9th)** Place the cylinder liner over the inner tube. Make sure the liner is tight against the top liner and use worm clamps to temporarily clamp the liner to the tube. Tack weld the bottom of the cylinder liner to the inner tube in three or four places. Remove the clamps when the cylinder liner is secured.

**7.11.23** Apply caulking to the seam on the cylinder liner and between the cylinder liner and top liner.

**7.11.24** Apply caulking around the top edge of the wall liner and top-inner edge on the inlet housing.

**7.11.25 (10th)** Align the reclaimer top assembly over the top of the reclaimer and lower it into place to match the mating holes in the flange, being careful not to smear the caulking. Secure the top bolts and inlet baffle bolts.

**7.11.26** Working through the reclaimer inlet, wipe the caulking seal smooth. Re-caulk any voids.

**7.11.27** Working through the reclaimer inlet, apply silicone caulking to seal seams around the inlet-side liner, inlet-top liner, and reclaimer weldment. Wipe the caulking smooth.

**7.11.28** Attach the inlet-pipe adaptor, replacing the gasket if worn, compressed, or otherwise damaged.

**7.11.29** If the lower flange gasket (usually installed on the blast machine flange) is worn, compressed, or otherwise damaged, clean old gasket material from the flange and install new 2" strip.

**7.11.30** Reattach the reclaimer to the blast machine.

**7.11.31** Install flex hoses.

**7.11.32** Allow time for the caulking to cure before putting the reclaimer in service.

## 7.12 Removing or Replacing Reclaimer Inlet Baffle – Figure 37

Only reclaimers with bolt-on tops.

When using lightweight media such as agricultural media or very fine media (180 and finer), as noted in Paragraph 1.11.6, good media may be carried over to the dust collector. To prevent lightweight-media carryover, the reclaimer inlet baffle can be removed. Review the following process before beginning to make sure all parts are available

### Installation Notes

Depending on conditions such as height and accessibility, it may be easier to replace the inlet baffle if the reclaimer is removed from the blast machine.

Make sure enough 13089 - 2" adhesive-backed gasket is available to replace compressed or damaged gaskets on the reclaimer upper flange (and lower flange if the reclaimer is removed from the blast machine).

- 900 cfm requires 7 ft at each flange.
- 1200 cfm requires 8 ft at upper flange and 7 ft at lower flange.

**7.12.1** Remove the reclaimer top.

**7.12.2** Remove the three bolts securing the baffle to the side of the reclaimer inlet and remove the baffle.

**7.12.3** Remove all caulking residue.

**7.12.4** Inspect the strip gasket on the reclaimer upper flange; replace it if damaged or compressed.

**7.12.5** If removing (not replacing) the baffle, remove the strip gasket from the inner tube and reinstall the

baffle bolts in the reclaimer holes. If replacing the baffle, skip to Paragraph 7.12.6.

**7.12.6** When replacing the baffle, make sure the strip gasket on the inner tube and the U-channel are in good condition and install the new baffle in reverse order. Apply silicone caulk to the seam (opposite side of the mounting bolts) between the baffle and reclaimer body. Wipe the caulk smooth.

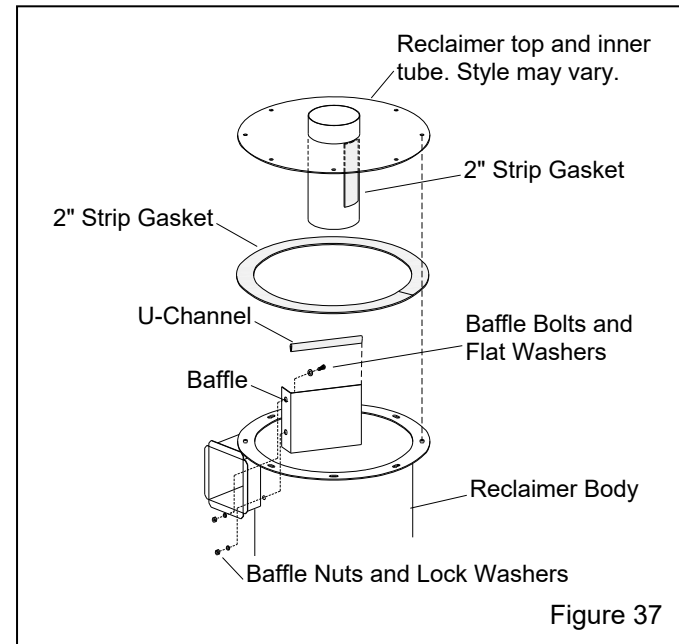

Figure 37

**7.12.7** Install the reclaimer top.

**7.12.8** If the reclaimer was removed from the blast machine, inspect the 2" flange gasket (usually mounted on the blast machine) if worn, compressed or otherwise damaged, clean old gasket material from the flange and install new 2" strip gasket.

**7.12.9** Reattach the reclaimer to the blast machine.

**7.12.10** If the baffle was replaced, allow the caulking to cure before putting the reclaimer into service.

## 7.13 Sentinel Metering Valve

**7.13.1** Refer to the Sentinel Metering Valve Owner's Manual, no. 20951 for service and replacement parts.

## 7.14 Reverse-Pulse Dust Collector

Reverse-pulse dust collectors are covered in a separate manual.

---

## 8.0 TROUBLESHOOTING

---

### WARNING

To avoid serious injury, observe the following when troubleshooting:

- Turn OFF the compressed-air supply, bleed the supply line, and lockout and tagout the air supply.
  - If checking the controls requires air, always enlist the aid of another person to:
    - Hold the nozzle holder securely.
    - Operate the foot pedal.
  - Never bypass the foot pedal or wedge it in the operating position.
  - Never bypass the door interlock system.
  - Follow all OSHA regulations, including lockout and tagout procedures.
- 

### 8.1 Poor visibility

**8.1.1** Dirty filter cartridge(s). Pulse cartridge and empty dust container regularly. Refer to the applicable dust-collector manual noted in Paragraph 1.1.1 to adjust pulse pressure and pulse sequence.

**8.1.2** Exhauster motor not operating. Check voltage to motor and motor wiring.

**8.1.3** Check rotation of exhauster motor; the motor should rotate as indicated by the arrow on the housing. If it does not rotate in the proper direction, **lockout and tagout electrical power** and switch the motor leads as shown on the motor plate. Refer to Section 2.11.

**8.1.4** Using friable media that rapidly breaks down, or using media that is too fine or worn out. Check condition of media.

**8.1.5** Dust-collector damper closed too far, restricting air movement through the cabinet. Adjust static pressure, per Section 5.3.

**8.1.6** Cabinet air-inlet damper closed too far, restricting air movement through the cabinet. Adjust damper, per Sections 2.13 and 5.6.

**8.1.7** Reclaimer door open. Check door.

**8.1.8** Hole worn in flex hose between cabinet hopper and reclaimer inlet or between the reclaimer and dust collector. Replace hose and route it with as few bends as possible to prevent wear.

**8.1.9** Obstruction in flex hose between the cabinet hopper and reclaimer inlet. Inspect flex hose for blockage.

**8.1.10** Nozzle worn. Replace the nozzle when its orifice diameter has increased by 1/16".

### 8.2 Abnormally high media consumption

**8.2.1** Door on reclaimer open or worn door gasket. Air entering reclaimer around the door will cause media carryover to the dust collector. Inspect door gasket. DO NOT operate unless all doors are closed.

**8.2.2** Dust-collector damper open too far. Adjust static pressure, per Section 5.3.

**8.2.3** Media may be too fine or worn out. Check condition of media.

**8.2.4** Using friable media that rapidly breaks down. Check condition of media.

**8.2.5** Blast pressure too high for the media, causing media to break down. Check blast pressure and adjust as needed or switch media.

**8.2.6** Hole worn in reclaimer or leak in reclaimer seams. Check entire reclaimer for negative-pressure leaks.

**8.2.7** Outlet valve not sealing. Inspect diaphragm.

**8.2.8** Metering valve requires adjustment. Adjust media flow, per Section 5.2.

**8.2.9** When using media finer than 180-mesh, the reclaimer inlet baffle may need to be removed. Refer to Section 1.11.6.

**8.2.10** Externally adjustable vortex cylinder requires adjustment; refer to Section 5.4. Option on cabinets with CDC-1 Dust Collector.

### 8.3 Reduction in blast cleaning rate

**8.3.1** Low media level. Check media level and replenish or replace as needed, per Section 4.1.

**8.3.2** Media-air mixture out of adjustment. Adjust metering valve, per Section 5.2.

**8.3.3** Reduced air pressure. This may be caused by the pressure regulator set to low, a malfunctioning regulator, a dirty filter element in air filter, partially closed air valve, leaking air line, or other air tools in use. Inspect all items.



**8.3.4** Blockage or partial blockage in nozzle. Blockage may occur because of a missing reclaimer debris screen. Inspect reclaimer screen.

**8.3.5** Moist media. Frequent bridging or blockage in the area of the metering valve can be caused by moisture. See Section 8.5.

**8.3.6** Air leaking through the outlet valve, reducing blast pressure and control pressure to media metering valve. Inspect diaphragm and outlet valve body.

#### **8.4 Plugged nozzle**

**8.4.1** A damaged or missing reclaimer screen will allow large particles to pass and block the nozzle. Replace or reinstall as necessary.

#### **8.5 Media bridging**

**8.5.1** Frequent bridging or blockage in the media metering valve can be caused by damp media. Media becomes damp from blasting parts that are slightly oily, from moisture in the compressed air, or from absorption from ambient air.

**8.5.2** To avoid contaminating media from the workpiece, all parts put into the cabinet should be clean and dry. If parts are oily or greasy, degrease and dry them prior to blasting.

**8.5.3** Moist compressed air may be due to a faulty compressor that overheats or pumps oil or moisture into the air line, too long of an air line permitting moisture to condense on the inside, or from high humidity. Drain filters and receiver tank regularly. Ongoing problems with moist air may require the installation of an air dryer or aftercooler in the air-supply line.

**8.5.4** Absorption. Some media types tend to absorb moisture from the air, especially fine-mesh media in areas of high humidity. Empty the media and store it in an airtight container when cabinet is not in use.

**8.5.5** A vibrator mounted either on the blast machine leg or on a bolt on the media metering valve may help to prevent bridging of fine-mesh media. **NOTE: To avoid the possibility of compressing media, a vibrator should be set up to start when the foot pedal is pressed and stop when the pedal is released.**

**8.6 Media surge:** A small amount of surge is normal at start-up.

**8.6.1** Heavy media flow. Adjust media, per Section 5.2.

**8.6.2** Empty the blast machine, depressurize the blast machine, and inspect the internal parts of the metering valve for wear. Refer to the Sentinel Media Metering Valve Manual, number 20951.

#### **8.7 Air only (no media) comes out the nozzle**

**8.7.1** Make sure the machine contains media.

**8.7.2** Make sure the media metering valve is open and media flow is adjusted, per Section 5.2.

**8.7.3** Make sure the blast machine is pressurized. See Section 8.9.

**8.7.4** Make sure the media metering valve opens when foot pedal is pressed. Refer to the metering valve owner's manual.

**8.7.5** Check for minor blockage in the media metering valve by fully opening the metering valve and closing the choke valve. Activate the foot pedal to blow out obstructions. If this procedure fails, depressurize the machine, remove the metering-valve inspection plate, and check for foreign objects.

**8.7.6** Check the muffler on the 4-way air valve. Air should exhaust from the muffler when the foot pedal is pressed. If air does not exhaust, remove the muffler and try again. If air exhausts now, the muffler is blocked. If air still does not exhaust, the 4-way valve may be faulty; refer to Paragraph 8.7.7 to check the 4-way valve.

**8.7.7** Check the 4-way valve as follows: Depressurize the air-supply line. Remove the tubing leading to either the media metering valve or diaphragm outlet valve. Pressurize the air-supply line. No air should exhaust from the tube adaptor. Press the foot pedal; air should start exhausting at the adaptor, and stop when pressure on the pedal is released. If it does not operate accordingly, the 4-way valve is faulty or air supply is insufficient.

**8.7.8** Outlet valve not sealing. Inspect diaphragm.

**8.7.9** Metering valve requires service. Refer to the media metering valve manual.

---

## 8.8 Neither media nor air comes out the nozzle when the foot pedal is pressed

**8.8.1** Depressurize the blast machine. After the pop-up valve has dropped, remove the nozzle to see if it is plugged. See Section 8.4.

**8.8.2** Make sure the blast machine pressurizes when the foot pedal is pressed. If it does not pressurize, refer to Section 8.9.

**8.8.3** Make sure the media metering valve and the choke valve are open.

## 8.9 Blast machine does not pressurize

**8.9.1** Make sure the air compressor is operating and air-supply valves are open.

**8.9.2** Make sure the pressure regulator is not set too low or OFF. Minimum pressure is 40 psi. Refer to Section 5.1.

**8.9.3** Door interlocks not engaging. Check door interlock adjustment, per Section 5.5.

**8.9.4** Inadequate air supply. Refer to the cfm air-consumption table in Figure 5.

**8.9.5** Inspect diaphragm in the outlet valve for wear.

**8.9.6** Inspect pop-up valve and seal for wear and misalignment.

**8.9.7** Blocked or leaking control line. Check all fittings and urethane tubing for blockage or leaks.

**8.9.8** Foot-pedal valve malfunction. Check foot pedal for alignment, and inlet and outlet lines for pressure.

**8.9.9** Make sure the lines are not reversed on the foot pedal or pilot regulator. Refer to the schematic in Figure 9.

**8.9.10** Check the 4-way valve for jamming, per Sections 8.7.6 and 8.7.7. When the foot pedal is pressed, the valve should shift, pressurizing the line to the outlet valve and media metering valve.

**8.9.11** Inspect the check valve (Figure 49, Item 18) for obstruction or broken flap.

---

## 8.10 Blast machine does not depressurize or depressurizes too slowly

**8.10.1** Check for blockage in the 4-way valve mufflers.

**8.10.2** Make sure the 3-way valve in the foot pedal exhausts air when the pedal is released. If it does not exhaust, check the inbound air line for blockage; if no blockage, replace the valve.

**8.10.3** Inspect brass control-line filter attached to diaphragm outlet valve for media blockage. If media is present, inspect outlet valve diaphragm for damage.

**8.10.4** Check the outlet muffler that is located inside the cabinet, for blockage.

**8.10.5** Check 4-way air valve for jamming, per Paragraphs 8.7.6 and 8.7.7.

## 8.11 Heavy media flow

**8.11.1** Make sure the choke valve is open.

**8.11.2** Media metering valve open too far. Adjust per Section 5.2. If adjusting the media valve does not regulate media flow, empty the machine, depressurize the machine, and inspect the internal parts of the valve for wear.

## 8.12 Media buildup in cabinet hopper; media does not convey to reclaimer

**NOTE: Do not pour media directly into the cabinet hopper, as overfilling may occur.** Overfilling will result in media carryover to the dust collector and possible blockage in the conveying hose.

**8.12.1** Exhauster motor rotating backward. The motor should rotate as indicated by the arrow on the exhauster housing. If it does not rotate in the proper direction, **lockout** and **tagout** electrical power and switch the motor leads, as shown on the motor plate. Refer to the system's wiring schematic. Refer to Sections 2.11.

**8.12.2** Dust-collector damper closed too far, restricting air movement through cabinet. Adjust static pressure, per Section 5.3.

**8.12.3** Dust-collector filter cartridge(s) clogged. Refer to the dust-collector owner's manual.

**8.12.4** Hole worn in flex hose between cabinet hopper and reclaimer inlet or between the reclaimer outlet and dust-collector inlet. Inspect hoses, replace them as

needed, and route them with as few bends as possible to prevent wear.

**8.12.5** Reclaimer door open. DO NOT operate unless door is closed.

**8.12.6** Obstruction in flex hose. Remove hoses and check for blockage.

### 8.13 Static shocks

**8.13.1** Cabinet and/or operator not grounded. Abrasive blasting creates static electricity. The cabinet must be grounded to prevent static buildup. See Sections 2.10 and the note in section 2.4.1. If shocks persist, the operator may be building up static. Attach a small ground wire, such as a wrist strap, from the operator to the cabinet.

**8.13.2** Gloves wearing thin. Inspect gloves and replace them as needed.

**8.13.3** Avoid holding parts and blasting off the grate. Static will buildup in the part if not dissipated through the metal cabinet. If blasting parts off the grate cannot be avoided, attach a ground wire between the cabinet and the part.

### 8.14 Dust leaking from cabinet

**8.14.1** Refer to Section 8.12.

### 8.15 Dust leaking from dust collector

**8.15.1** Cartridge(s) not seasoned; refer to the dust-collector owner's manual to season cartridge(s)

**8.15.2** Damaged or loose filter cartridge(s). Inspect filters, replace as needed.

Refer to the dust-collector owner's manual to service reverse-pulse dust collectors.

## 9.0 ACCESSORIES AND REPLACEMENT PARTS

### 9.1 Optional Accessories

Conversion kits to convert from push-thru reclaimer with dry filter to pull-thru for use with reverse-pulse dust collector.

Description	Stock No.
To convert from dry filter to CDC-1 Dust Collector Kit includes outlet adaptor pipe, gasket, and fasteners. for 900 cfm reclaimer .....	28964
To convert from dry filter to RPC or RPH Dust Collector. Kit includes pull-thru adjustable vortex, gasket, and fasteners for 900 cfm reclaimer .....	28630
Conversion kits, Sentinel Metering Valve To convert from fine-mesh media to coarse .....	22848
To convert from coarse-mesh media to fine .....	22849
Time delay door locks .....	24164
Lock pins (pkg of 25) for twist-on hose couplings ..	11203
Safety cable, 1/2" OD to 1-1/4" OD blast hose .....	15012
Manometer kit .....	12528
Noise-reduction arm port covers, pair .....	24885
Anti-fatigue floor-mat, 2 ft x 3 ft, for front of cab. ....	24744
Abrasive trap .....	02011
Aluminum oxide kit, <u>factory-installed</u> : Includes #3 boron carbide lined nozzle, black-rubber cabinet wall curtains with grommets and curtain hardware. Does <u>not</u> include rubber reclaimer liners.	
6012 with 900 cfm .....	27769
6012 with 1200 cfm .....	27782
7212 with 900 cfm .....	27784
7212 with 1200 cfm .....	27786
Aluminum oxide kit, <u>field installed</u> or replacement kits: Includes #3 boron carbide lined nozzle, heavy-lined flex hoses, black-rubber curtains with grommets and curtain hardware. Does not include rubber reclaimer liners.	
6012 with 900 cfm .....	25493
6012 with 1200 cfm .....	25495
7212 with 900 cfm .....	25518
7212 with 1200 cfm .....	25520
Boron carbide nozzle	
CTB-2, 1/8" orifice .....	21090
CTB-3, 3/16" orifice .....	21091
CTB-4, 1/4" orifice .....	21092
Rubber curtain set, black	
for 6012 .....	27768
for 7212 .....	27746
Rubber curtain set, white	
for 6012 .....	27767
for 7212 .....	27745

HEPA Filter, for use with reverse-pulse dust collectors  
 900 cfm free standing .....23626  
 1200 cfm freestanding floor mount.....23627

Flex hose, heavy-lined, for heavy usage with aluminum oxide. Available in 15 ft lengths only.  
 4" ID for 900 cfm .....12473  
 5" ID for 1200 cfm .....12465  
 6" ID for 900 cfm .....12457  
 7" ID for 1200 cfm .....12459

Supa hose, bulk 3/4" ID, uncoupled, specify ft req'd .23100  
 NOTE: Supa hose requires the use of the following coupling, contractor-thread nozzle holder, and nozzle.

Nozzle holder, NHP-3/4 w/contractor thread .....11398  
 Coupling, CQPS-3/4 for 3/4" Supa hose .....11395  
 Gasket, CQGP-1, for 11395-3/4" Supa hose coupling, pack of 10 .....08852

Nozzle, short venturi for use with 3/4" ID Supa hose  
 TYP-3, 3/16" orifice .....23501  
 TYP-4, 1/4" orifice .....23502  
 TYP-5, 5/16" orifice .....23503

Turntables and Turntables with Tracks

**WARNING**

**Turntable capacities are based on concentric loading. Use solid fixturing to hold heavy parts in place. Do not remove lift equipment until the part is adequately supported to prevent movement. Moving or rotating heavy, unsupported or off-centered parts may cause them to shift or topple, and cause severe injury.**

**Fixed-Base Turntable with Bearing, 500 lb. Capacity – Figure 38**

Item	Description	Stock No.
(-)	30" diameter turntable assembly .....	14138
(-)	40" diameter turntable assembly .....	24042
(-)	48" diameter turntable assembly .....	13845
1.	Turntable, replacement	
	30" diameter 500 lb capacity .....	21390
	40" diameter 500 lb capacity .....	23879
	48" diameter 500 lb capacity .....	21400
2.	Bearing, 1-1/2" bore (48" table requires 2)..	11517
3.	Protector, bearing .....	13479
4.	Bolt, 1/2-NC	
	2" long for 30" and 40" turntable .....	03456
	2-1/2" long for 48" turntable .....	03457
5.	Lock-washer, 1/2" .....	03516
6.	Nut, 1/2-NC hex .....	03511

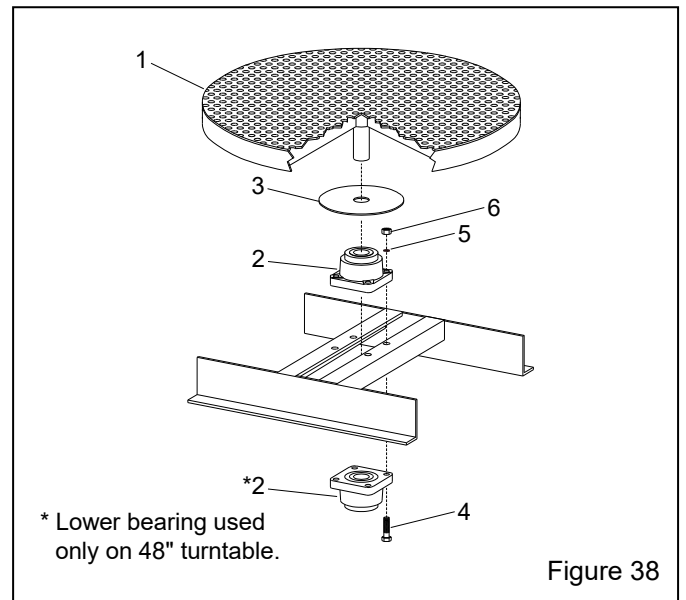

Figure 38

**Turntable with Workcar and Track**

2000 lb. capacity turntable mounted on workcar with 9 ft. (nominal) track extension

30" diameter for BNP-6012 .....	25550
48" diameter for BNP-6012 .....	27055
48" diameter for BNP-7212 .....	25555

**Turntable with Workcar, 500 lb - 2000 lb Capacity  
Figure 39**

Item	Description	Stock No.
1.	Turntable, replacement 30" diameter, 500 lb/2000 lb capacity ....	21390
	48" diameter, 500 lb/2000 lb capacity ....	21400
2.	Bearing, 1-1/2" bore, 1 req'd for 30" table 2 required with 48" table .....	11517
3.	Protector, bearing .....	13479
4.	Wheel, 6" V groove .....	12220
5.	Bolt, 1/2" shoulder .....	13477
6.	Washer, 1/2" flat .....	03515
7.	Nut, 3/8 lock .....	03312
8.	Bolt, 1/2-NC 2" long for 30" turntable .....	03456
	2-1/2" long for 48" turntable .....	03457
9.	Washer, 1/2" lock .....	03516
10.	Nut, 1/2-NC hex .....	03511
11.	Pin, quick release .....	25540

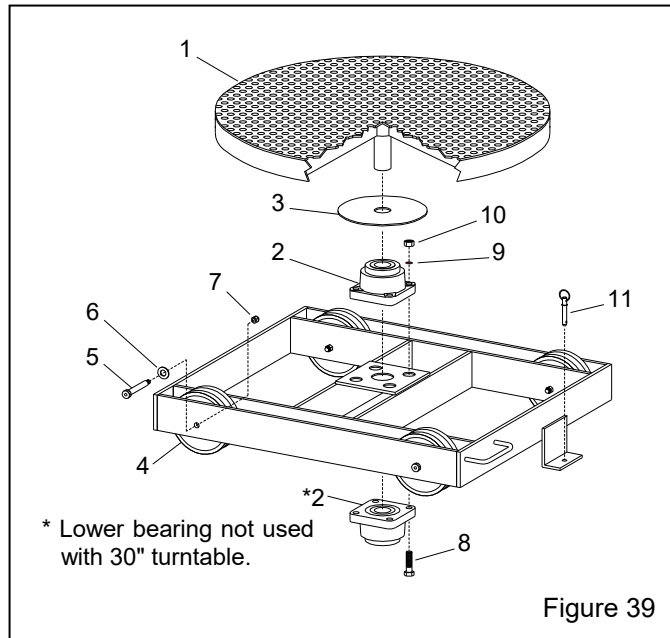

**Abrasive Trap – Figure 40**

Item	Description	Stock No.
(-)	Abrasive trap, complete .....	02011
1.	Screen .....	02012
2.	O-Ring .....	02013
3.	Cap .....	02014
4.	Body .....	02015
5.	Lock bar .....	02016
6.	Screw, 3/8" x 1" thumb .....	03289
7.	Shoulder screw, 3/8" x 3/8" .....	03291
8.	Gasket, screen .....	02434
9.	Label, "clean screen at least twice daily" ...	02129
(-)	Service kit (items 1, 2, 8 and 9) .....	01925

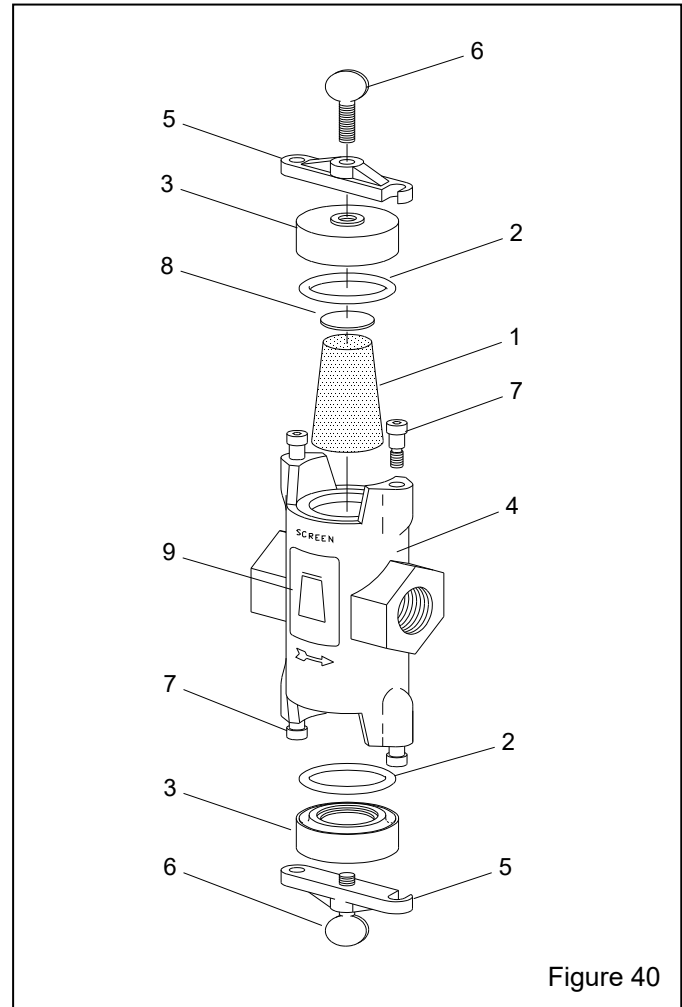

**Reclaimer Liners – Figure 41**

Reclaimer must be designed to accept liners and have a removable top.

Item	Description	Stock No.
(-)	Rubber liner sets	
	900 cfm .....	23151
	1200 cfm .....	25439
	1800 cfm .....	23153
1.	Top liner	
	900 cfm .....	23059
	1200 cfm .....	22689
	1800 cfm .....	22695
2.	Baffle, lined	
	900 cfm .....	13694
	1200 cfm .....	25437
	1800 cfm (one piece - includes Item 3) ..	22696
3.	Inner cylinder liner	
	900 cfm .....	24203
	1200 cfm .....	25438
4.	Wall liner, reclaimer body	
	900 cfm .....	17008
	1200 cfm .....	25436
	1800 cfm .....	22697
5.	Inlet-side liner	
	900 cfm .....	12830
	1200 cfm .....	22693
	1800 cfm .....	22698
6.	Cone liner	
	900 cfm .....	16070
	1200 cfm .....	22694
	1800 cfm .....	22699
7.	Inlet-top	
	900 cfm .....	22827
	1200 cfm .....	24031
	1800 cfm .....	24032
8.	Screw, 10-16 x 3/4" self-drill/tap .....	12722

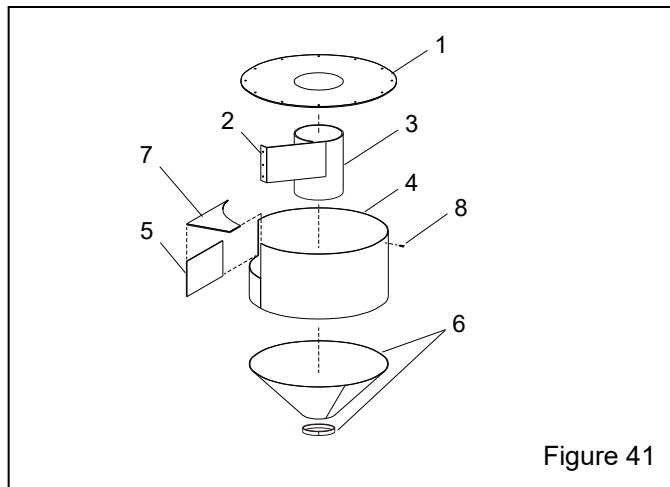

**Armrest – Figure 42**

Item	Description	Stock No.
(-)	Armrest assembly for one station .....	24900
1.	Armrest, replacement .....	24899
2.	Bracket, armrest cabinet, each .....	24896
3.	Support bar, adjustable, each .....	24895
4.	Cap screw, 3/8-NC x 1" .....	03252
5.	Washer, 3/8 lock .....	03318
6.	Cap screw, 5/16-NC x 1" .....	03152
7.	Nut, 5/16-NC hex .....	03211
8.	Washer, 5/16 flat .....	03216
9.	Washer, 5/16 lock .....	03217

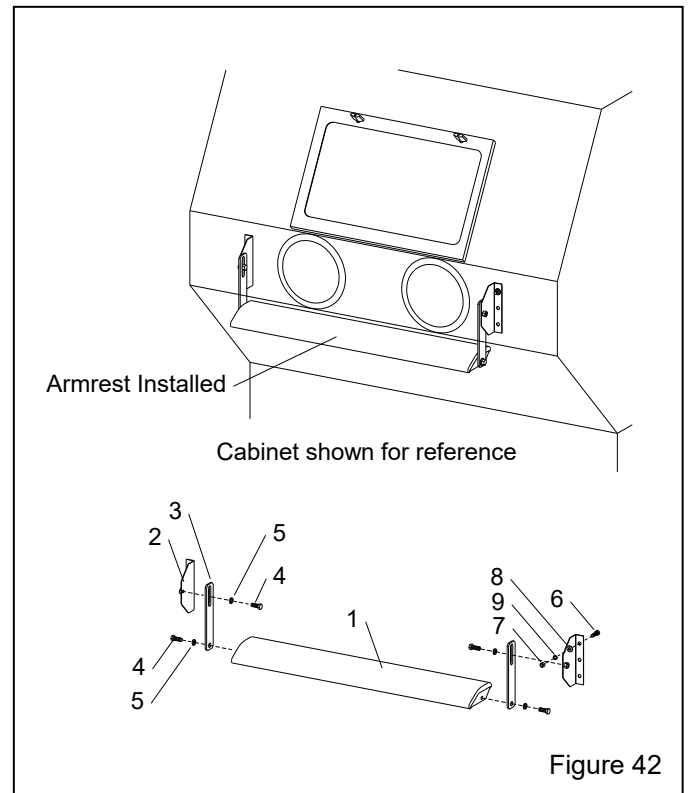

9.2 Cabinet Replacement Parts – Figure 43

Item	Description	Stock No.
1.	Gasket, door, adhesive-backed, per foot, 24 ft. for 6012, 28 ft. for 7012	21236
2.	Gasket, 5/32" x 3/4" adhesive backed, 6 ft required at each light cutout	00192
3.	Grate, slotted front	
	for 6012	25155
	for 7212	12971
4.	Grate, unslotted	
	for 6012	25154
	for 7212 (3 required)	12970
5.	Glove set	
	Band-clamp attachment	11215
	Quick-Change (clampless) attachment	28820
6.	Glove, left hand only	
	Band-clamp attachment	12710
	Quick-Change (clampless) attachment	28638
7.	Glove, right hand only	
	Band-clamp attachment	12711
	Quick-Change (clampless) attachment	28639
8.	Clamp, for clamp-attached glove	11576
9.	Grommet, blow off hose	11798
10.	Grommet, blank	13666
11.	Support, blast hose	16554

12.	Gasket, blast hose support adaptor	13426
13.	Muffler, outlet	05068
14.	Foot pedal assembly, less tubing, includes items 1 thru 9	20483
	with tubing, w/14 ft item 10	20195
15.	Bracket, door interlock actuator	19152
16.	Over-travel stop, door interlock	20004
17.	Detent sleeve, door interlock	15042
18.	Valve, 1/8", 3-way air, door interlock	12202
19.	Fitting, straight, 1/8" NPT x 1/8" barb	11732
20.	Eyebolt, 5/8"	13421
21.	Regulator, 1/4-NPT pilot with gauge	12050
22.	Gauge, 1/4" NPT cbm pressure	11826
23.	Bushing 1/4" x 1/8" NPT	02010
24.	Fitting, 1/8" NPT elbow x 1/8" barb	11733
25.	Bracket, pressure regulator	22358
26.	Gasket, 5/16" x 1" adhesive-backed, per foot, specify feet required	00187
27.	Damper, air inlet	23156
28.	Baffle, air intake	25912
29.	Nipple, 1" x close	01701
30.	Tee, 1" pipe	01789
31.	Plug, 1" pipe	01761
32.	Nut, 1" lock	11917
33.	Coupling, 1"-NPT pipe	01830

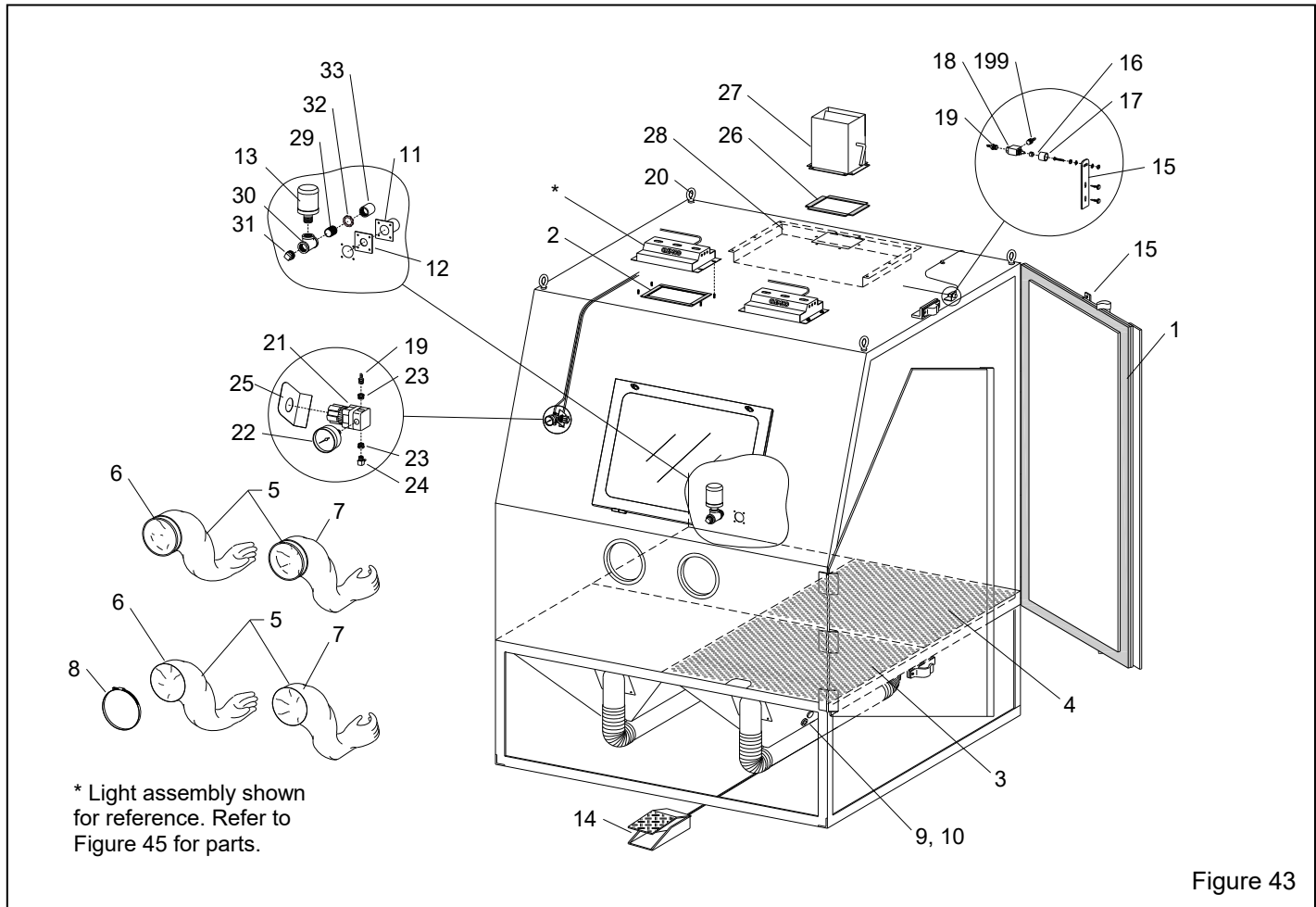

Figure 43

**9.3 View-Window Assembly – Figure 44**

Item	Description	Stock No.
1.	Window glass, 20" x 30" laminated .....	12213
2.	Gasket, 5/16" x 3/4", applied to cabinet per foot, 9 feet required .....	00189
3.	Gasket, 5/32" x 3/4", applied to window Frame, per foot, 9 feet required .....	00192
4.	Cover lens, 20" x 30", pack of five .....	23232
5.	Nut, plastic, window frame, 2 required .....	23035
6.	Window frame, 20" x 30" quick change ....	23245

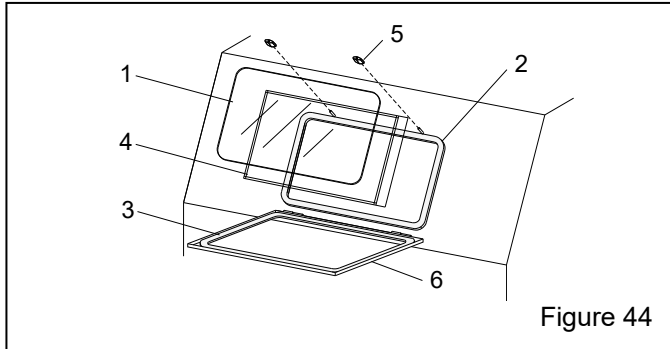

Figure 44

**9.4 LED Light Assembly – Figure 45**

Item	Description	Stock No.
1.	Cover, LED light mount .....	29712
2.	LED light module, 50 watt .....	29711
3.	Diffuser lens .....	23253
4.	Gasket, 5/32" x 3/4" adhesive backed, 6 ft required at each cutout .....	00192
5.	Strain relief connector .....	11631
6.	Locknut, 1/2" conduit .....	12713
7.	Nut, 1/4" NC hex .....	03111
8.	Washer, 1/4" lock .....	03117
9.	Washer, 1/4" flat .....	03116

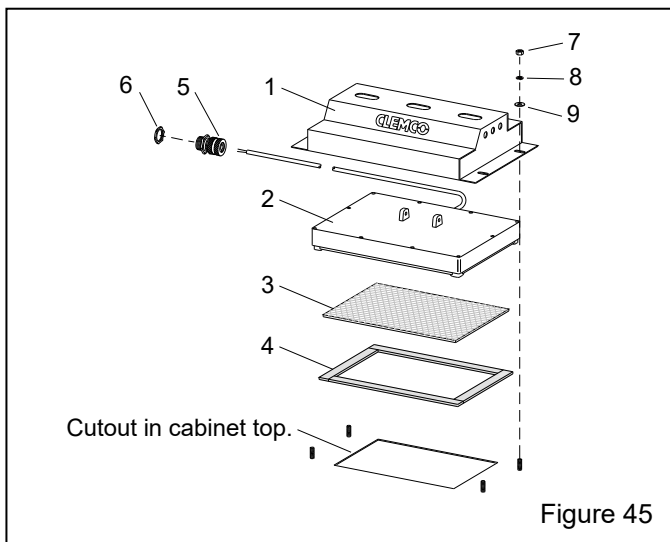

Figure 45

**9.5 Foot-Pedal Assembly – Figure 46**

Item	Description	Stock No.
(-)	Foot-pedal assembly, less tubing, includes items 1 thru 9 .....	20483
	with tubing, w/14 ft Item 10 .....	20195
1.	Foot pedal casting set, top and base .....	28379
2.	Valve, 10-32, 3 way n/c .....	20026
3.	Drive pin, grooved .....	20109
4.	Screw, sh 1/4 NF x 3/4" .....	03086
5.	Screw, 10-32 x 1/2" fh .....	19571
6.	Adaptor, 10-32 thread x 1/8 barb .....	11731
7.	Spring, 1-1/4" x 3-1/2" .....	20121
8.	Screw, 8-32 x 3/8" thread cutting .....	11389
9.	Bumper, rubber (feet) .....	21522
10.	Tubing, 1/8" ID twin, specify ft required ...	19577
11.	Tie, nylon wire .....	12139

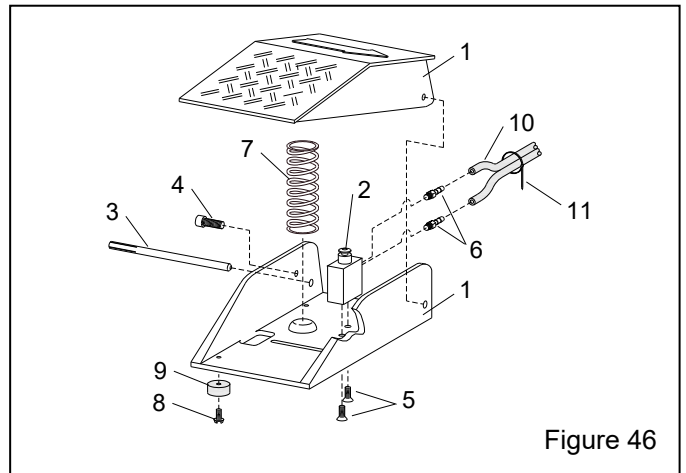

Figure 46

**9.6 1" Diaphragm Outlet Valve – Figure 47**

Item	Description	Stock No.
(-)	1" Diaphragm outlet valve, complete .....	03371
1.	Nipple, 1" x close .....	01701
2.	Diaphragm, outlet valve .....	06149
3.	Washer, 1/4" lock .....	03117
4.	Screw, 1/4" x 1" HH Cap .....	03053
5.	Cap, diaphragm outlet .....	03393
6.	Body, diaphragm outlet .....	06135
7.	Bushing, 1-1/4" x 1" .....	01804

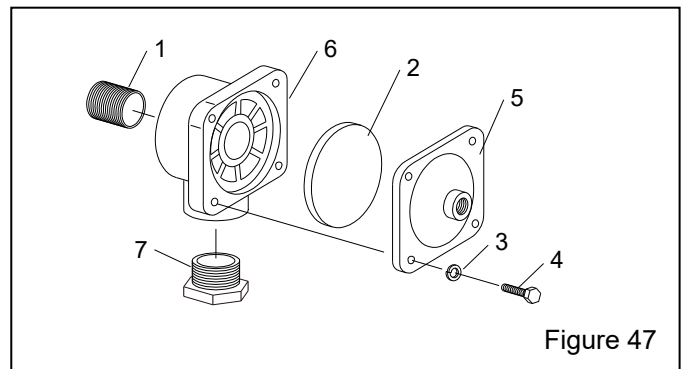

Figure 47



9.7 Plumbing and Cabinet Controls – Figure 48

Item	Description	Stock No.
1.	Valve, 3 way	12202
2.	Fitting, straight, 1/8" NPT x 1/8" barb	11732
3.	Tubing, 1/8" ID urethane, specify ft. reqd. ...	12475
4.	Tubing, 1/8" ID twin urethane specify feet required	19577
5.	Fitting, straight 1/4" NPT x 3/8 tube	11736
6.	Tubing, 3/8" OD poly, specify ft. required ...	12478
7.	Tee, 1/8" tube barb	11734
8.	Filter, 1" w/ auto drain	22425
9.	Adaptor, 1" male NPT x 1" male flare	11720
10.	Valve, 4-way air	12203
11.	Fitting, elbow 1/4" male NPT x 3/8 tube	11685
12.	Valve, diaphragm outlet	03371
13.	Nipple, 1/4" Hex	02808
14.	Tee, 1/4" brass	02025
15.	Bushing 1/4" x 1/8" NPT	02010
16.	Hose assembly, 1" x 10' exhaust	23915

17.	Muffler, 1/4" bronze	03988
18.	Adaptor, 1/2" NPT x 1/2" male flare	11351
19.	Hose end, 1/2" barb x 1/2" female swivel	15002
20.	Hose end, 1/2" barb x 3/8" male NPT	06369
21.	Blow-off nozzle	13116
22.	Hose, 1/2" ID air, specify feet required	12472
23.	Regulator 1/4"-NPT pilot with gauge	12050
24.	Gauge, 1/4" NPT cbm pressure	11826
25.	Fitting, 1/8" NPT elbow x 1/8" barb	11733
26.	Foot pedal assembly, less tubing	20483
	with tubing, 14 feet item 4	20195
27.	Media metering valve, Sentinel for 50-mesh and finer media	21439
	for media coarser than 50-mesh	20608
28.	Regulator, 1" pilot operated w/ gauge	12052
29.	Gauge, 1/4" cbm	11830
30.	Filter, 1/4" NPT male/female inline	27618
31.	Plug, 1/4" pipe	01950

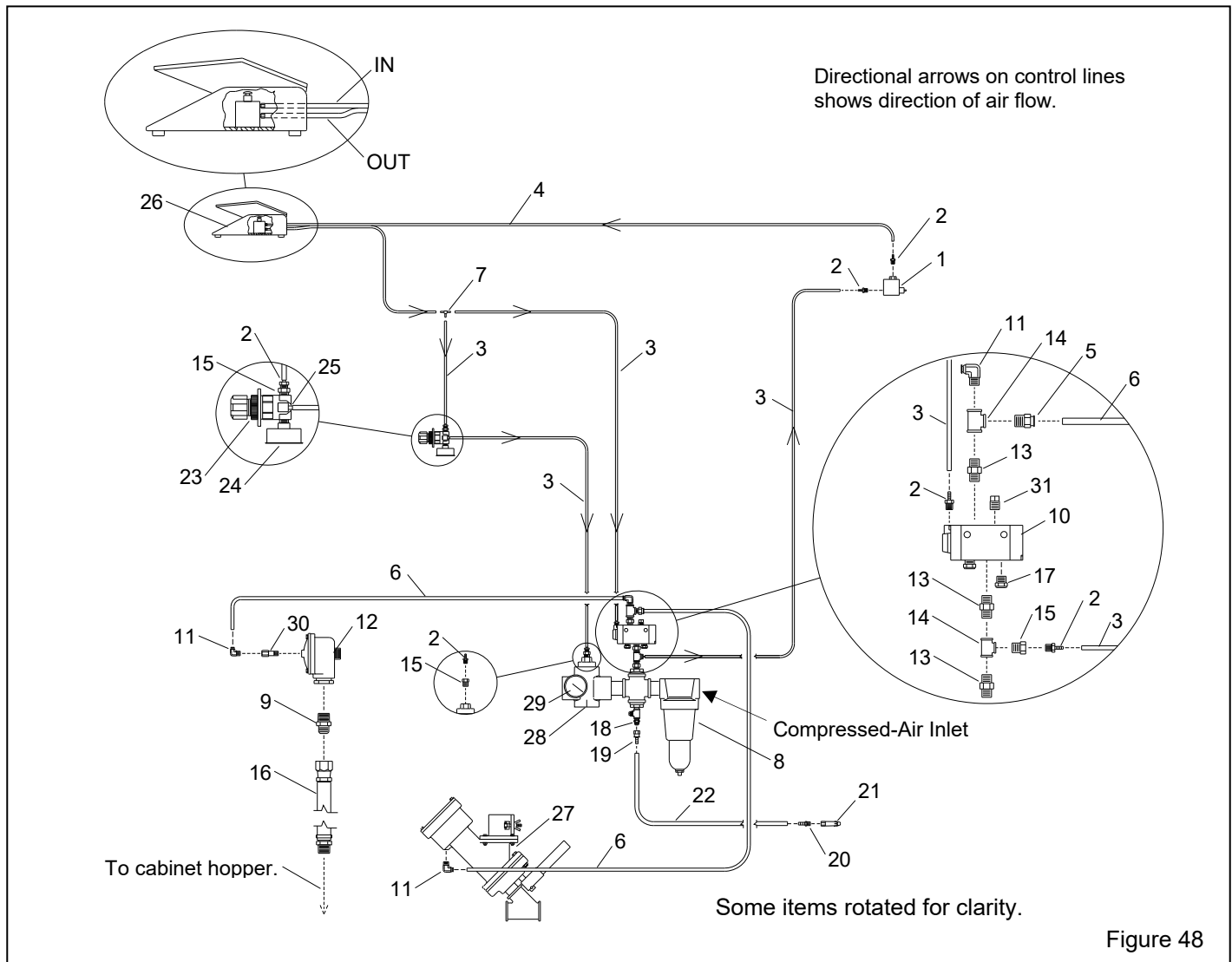

9.8 Blast Machine – Figure 49

Item	Description	Stock No.
(-)	Blast machine assembly, 16" dia., 2 cuft capacity	21135
1.	Ball valve, 1" with handle (choke valve)	02396
2.	Handle, 1" ball valve	22531
3.	Leg pad, right for 1642	20735
4.	Leg pad, left for 1642	20736
5.	Adaptor, 1" male NPT x 1" male flare	11720
6.	Hose assembly, 1" x 21" pusher line	22508
7.	CF Coupling 1-1/4" NPT	00551
8.	Media metering valve, Sentinel for 50-mesh and finer media, standard	21439
	for 50-mesh and coarser media	20608
9.	Inspection door assembly, 6" x 8"	02377
10.	Gasket, 6" x 8" inspection door	02369
11.	Pop-up valve with external sleeve	03699
12.	Guide, pop-up, 1-1/4" x 6-1/2" toe nipple	01754
13.	Seal, pop-up valve	02325
14.	Valve, 1" diaphragm outlet	03371
15.	Regulator, 1" pilot operated w/ gauge	12052
16.	Gauge, 1/4" cbm	11830

17.	Filter, 1" w/ auto drain	22425
18.	Check valve, 1" swing	12187
19.	Valve, 4-way air	12203
20.	Gasket, CQG, pkg of 10	00850
21.	Coupling, 1/2" ID hose, CQA-1/2	00599
22.	Nozzle holder, CHE-1/2	00577
23.	Blast hose, 1/2" ID x 16 ft coupled, includes items 21 & 22	01251
24.	Nozzle, tungsten carbide CT-2, 1/8" orifice	01351
	CT-3, 3/16" orifice, standard	01352
	CT-4, 1/4" orifice	01353
25.	Nozzle washer, NW-1, pkg. of 10	21580
26.	Fitting, elbow 1/4" M-NPT x 3/8" tube	11685
27.	Fitting, straight 1/4" M-NPT x 3/8" tube	11736
28.	Muffler, 1/4" bronze	03988
29.	Hose assembly, 1" x 10' exhaust	23915
30.	Filter, 1/4" NPT male/female inline	27618
31.	Lock pin, coupling (package of 25)	11203

9.9 Sentinel Valve Replacement Parts

Refer to the Sentinel Valve owner's manual no. 20951 for replacement parts.

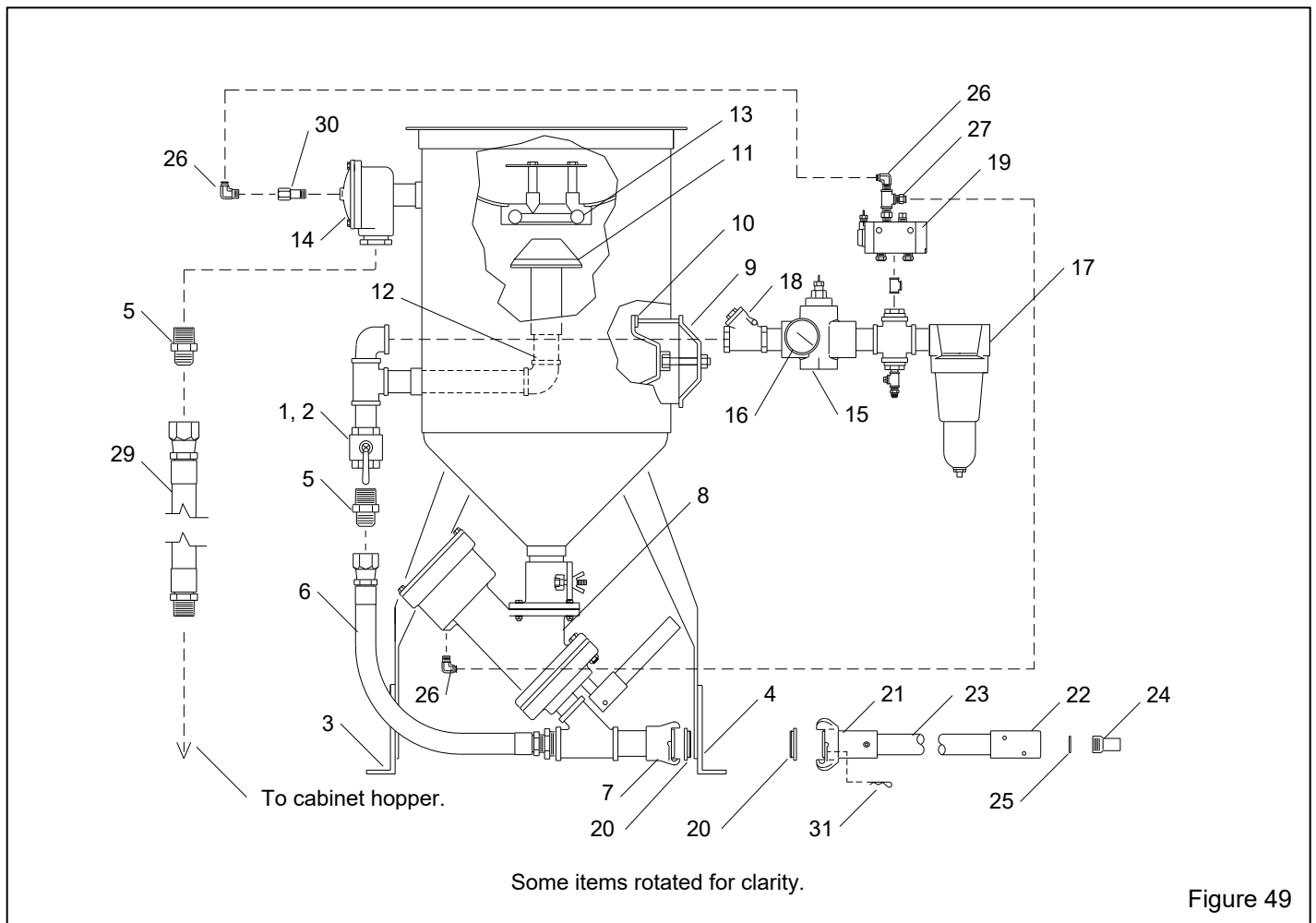

Figure 49

**9.10 Flex Hose, Wye Pipe, and Adaptors**  
**Figure 50**

All hose is sold per foot unless noted, specify feet required. Some trimming may be necessary.

Item	Description	Stock No.
1.	Hose, light-lined flex, 2-ft required per side 4" ID for 900 cfm conventional use .....	12466
	4" ID for 1200 cfm w/steel media .....	12466
	5" ID for 1200 cfm conventional use .....	12467
	5" ID for 1800 cfm w/steel media .....	12467
	6" ID for 1800 cfm conventional use .....	12468
2.	Hose, light-lined flex, 5-ft required per side 4" ID for 900 cfm conventional use .....	12466
	4" ID for 1200 cfm w/steel media .....	12466
	5" ID for 1200 cfm conventional use .....	12467
	5" ID for 1800 cfm w/steel media .....	12467
	6" ID for 1800 cfm conventional use .....	12468
3.	Hose, light-lined flex, 9-ft required 6" ID for 900 cfm conventional use .....	12468
	6" ID for 1200 cfm w/steel media .....	12468
	7" ID for 1200 cfm conventional use .....	12469
	7" ID for 1800 cfm w/steel media .....	12469
	8" ID for 1800 cfm conventional use .....	12470
4.	Hose, unlined flex, specify feet required 7" ID for 900 cfm .....	12448
	12" ID for 1200 and 1800 cfm w/RPH .....	12460
5.	Clamp, hose for 4" hose .....	11577
	for 5" hose .....	11578
	for 6" hose .....	00750
	for 7", 8" hose .....	11576
	for 12" hose, 2 required .....	11576

6.	Wye pipe adaptor, 4" x 4" x 6" 900 conv'l and 1200 cfm w/steel .....	12379
	5" x 5" x 7" 1200 conv'l and 1800 cfm w/steel .....	16939
	Consult Clemco distributor for larger sizes	
7.	Air intake adaptor, hopper, each 4" for 900 cfm conventional use .....	24526
	4" for 1200 cfm w/steel media .....	24526
	5" for 1200 cfm conventional use .....	24527
	5" for 1800 cfm w/ steel media .....	24527
	6" for 1800 cfm conventional use .....	24528
8.	Hopper transition tubes, bolt on, each 4" for model 6012, 900 conv. and 1200 cfm w/steel .....	24517
	5" for model 6012, 1200 conv'l and 1800 cfm w/steel .....	24518
	6" for model 6012, 1800 cfm conv'l .....	24519
	4" for model 7212, 900 conv'l and 1200 cfm w/steel .....	24534
	5" for model 7212, 1200 conv'l and 1800 cfm w/steel .....	24535
	6" for model 7212, 1800 cfm conv'l .....	24536
9.	Gasket, 5/16" x 1" adhesive-backed, per foot, specify feet required .....	00187
10.	Hose, heavy lined, 15 foot lengths only Provided with aluminum oxide kits 4" ID for 900 cfm .....	12473
	5" ID for 1200 cfm .....	12465
11.	Hose, heavy lined, 15 foot lengths only Provided with aluminum oxide kits 6" ID for 900 cfm .....	12457
	7" ID for 1200 cfm .....	12459

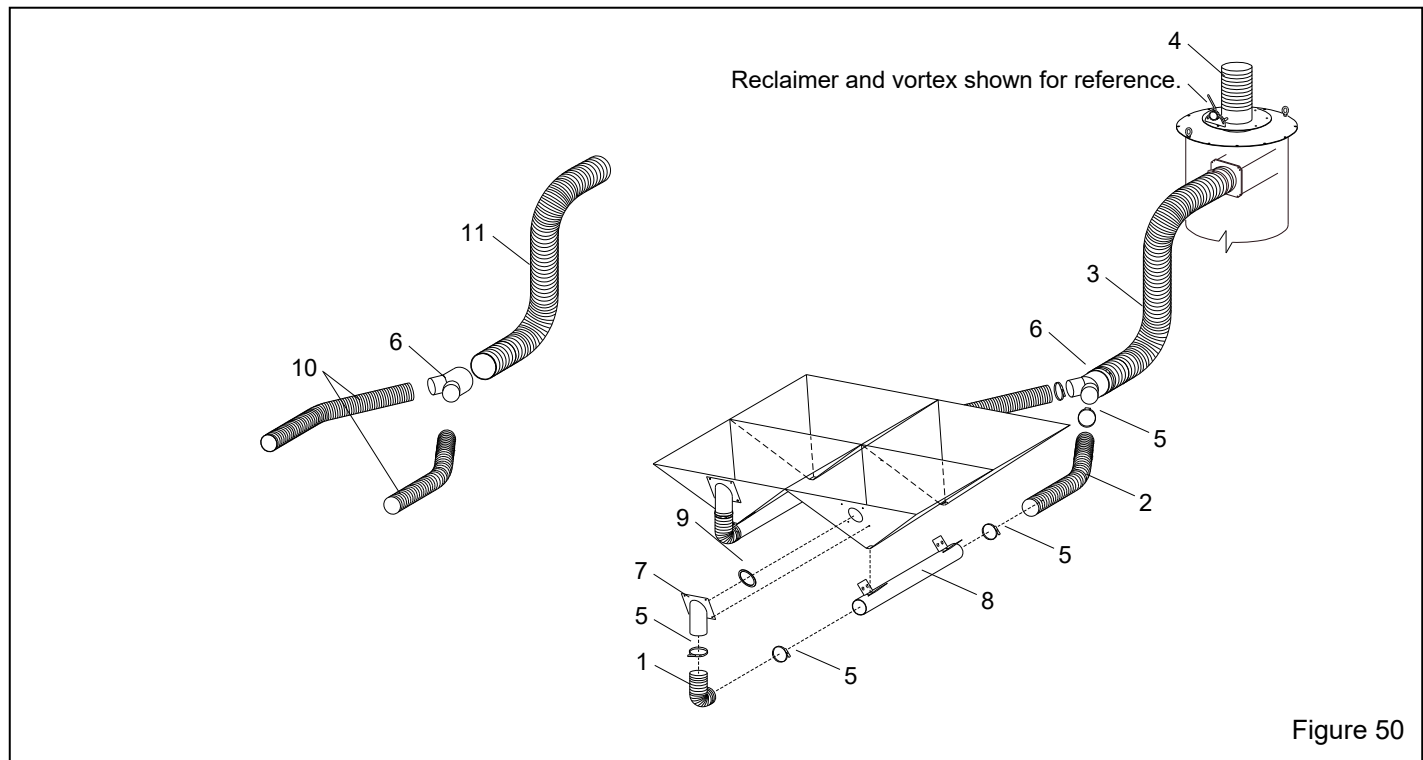

Figure 50

**9.11 Replacement Reclaimer Assemblies**

Replacement reclaimers are pull-thru type for w/16" dia. flange for 2 cu. ft. blast machine for use with reverse-pulse dust collectors; they include the hose inlet, screen, and wear plate, they do not include metering valve, flex hoses, hose clamps, or mounting brackets. Order separately when needed.

Description	Stock No.
900 cfm reclaimer w/ 7" outlet pipe adaptor	28969
900 cfm reclaimer w/external adjustable vortex	21293
1200 cfm reclaimer w/external adjustable vortex	24066

**9.12 900 CFM Reclaimer, for 16" Diameter Blast Machine – Figure 51**

Item	Description	Stock No.
(-)	Reclaimer assembly, pull-thru type	
	900 cfm reclaimer with 7" outlet plate	28969
	900 cfm w/external adjustable vortex	21293
1.	Gasket, 5/16" x 1" adhesive-backed, 5 feet required	00187
2.	Inlet pipe adaptor, 6"	12363
3.	Gasket, inlet pipe adaptor, 6"	11759
4.	Wear plate, rubber-lined w/mntg screws 900 cfm with bolt-on top	25071

5.	Screen assembly, 8-mesh	21265
6.	Door assembly, w/gasket and latch	14271
7.	Gasket, door	11745
8.	Latch assembly, door	12263
9.	Gasket, 2" adhesive-backed, per foot, specify ft required	13089
10.	Outlet plate, 900 cfm with 7" pipe	16832
11.	Top assembly, 900 cfm	23040
12.	Eyebolt 3/8-NC	00430
13.	Adaptor, 16" dia. blast machine, used on 900 cfm only	23043
14.	U-channel, 3/8, 1-foot required	04076
15.	Baffle, 900 modular	23051
16.	Gasket, 1/8" x 2" adhesive-backed, per foot, 1 foot required at this location	13089
17.	Body section, unlined, with door, wear plate, and baffle	27465
18.	Body section with rubber liners, door, and item 11 bolt-on top assembly	27466
*19.	Clamp, hose, 6-1/2" for 6" hose	00750
*20.	Hose support, inlet – option for 900 cfm, 6" standard use	16887
*21.	Hose support, 7" outlet – option	20619
*22.	Clamp, 8" for 7" hose	11576
*23.	Hose, 7" ID unlined flex, specify length	12448
**24.	Vortex cylinder assembly, adjustable, 900 cfm pull-thru	23046

**900 CFM MODULAR RECLAIMER**

\* Items marked with an asterisk (\*) are not included with replacement reclaimers. If those items are needed, they must be ordered separately.

\*\*The vortex cylinder is optional with cabinets provided with a CDC-1 Dust Collector, but standard on cabinets provided with an RPC-2 or RPH-2 Dust Collector.

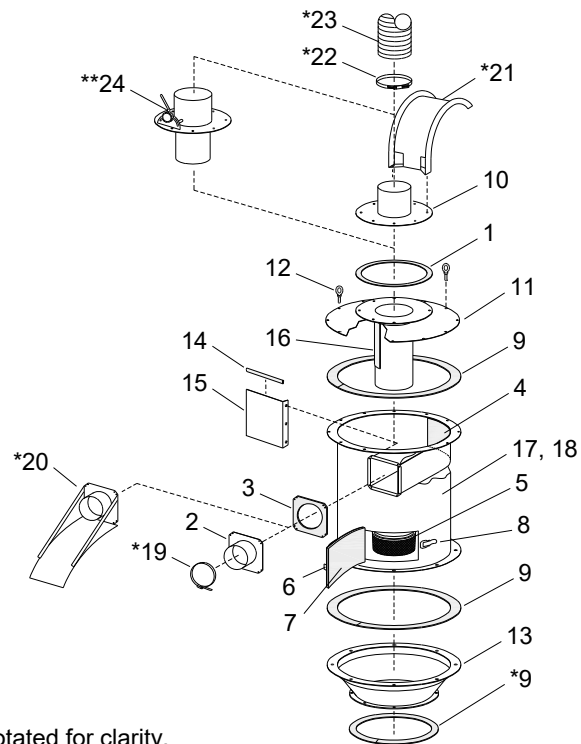

Some items rotated for clarity.

Figure 51

**9.13 1200 CFM Reclaimer, for 16" Diameter Blast Machine – Figure 52**

Item	Description	Stock No.
(-)	Reclaimer assemblies, pull-thru w/16" dia. flange for 2 cu. ft. blast machine 1200 w/externally adjustable vortex	24066
1.	Gasket, 5/16" x 1" adhesive-backed, per foot, specify feet required	00187
2.	Hose support, inlet	
	6", 1200 cfm for steel grit	22729
	7", 1200 cfm conventional	20596
	8", 1800 cfm conventional	20597
3.	Gasket, inlet adaptor	
	1200 cfm	11767
	1800 cfm	11765
4.	Wear plate, rubber-lined w/mntg screws	
	1200 cfm	19223
	1800 cfm	23028
5.	Screen assembly, No. 8-mesh	21265
6.	Gasket, door	
	1200 cfm and 1800 cfm	11766

7.	Latch assembly, door	12263
8.	Baffle, 1200 cfm	24903
9.	Gasket, 1/8" x 2" adhesive-backed, per foot, specify feet required	13089
10.	Eyebolt 3/8-NC	00430
11.	Vortex cylinder, externally adjustable	
	1200 cfm, 12"	25432
	1800 cfm, 12"	19090
12.	Top plate, 1200 cfm	24057
13.	U-channel, 3/8, 1-foot required	04076
14.	Gasket, 1/8" x 2" adhesive-backed, per foot, 1 foot required at this location	13089
15.	Hopper and leg assembly, 1200 cfm, for 16" dia. blast machine	24063
*16.	Hose support, outlet, optional	
	1200/1800 cfm	20730
*17.	Clamp, hose	
	6-1/2" for 6" hose	00750
	7" and 8" hose	11576
*18.	Hose, unlined flex, specify feet required	
	12" ID for 1200 and 1800 cfm	12460
*19.	Clamp, 2 required for 12" hose	11576

**1200 CFM MODULAR RECLAIMER**

\* Items marked with an asterisk \* are not included with replacement reclaimers. If those items are needed, they must be ordered separately.

Some parts may be rotated for clarity.

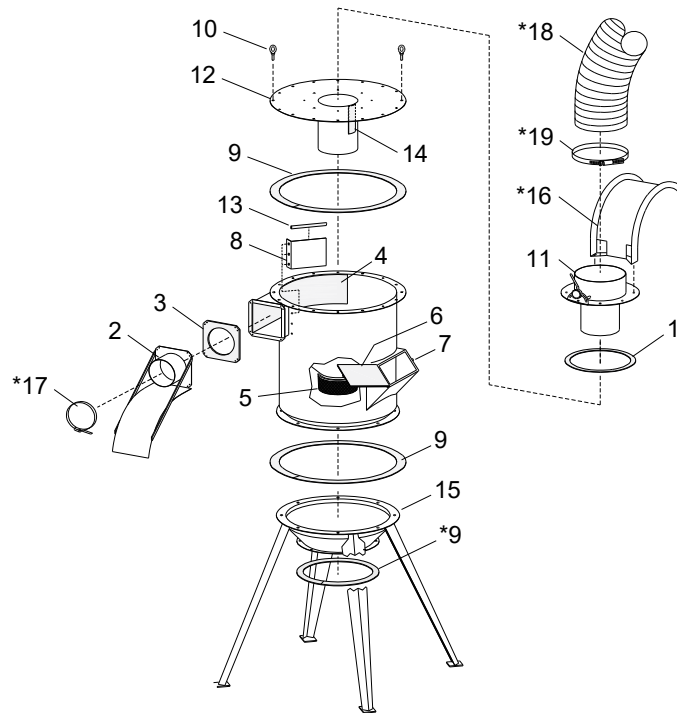

Figure 52